



ZAPI[®] S.p.A.

**ELECTRONIC • OLEODYNAMIC • INDUSTRIAL
EQUIPMENTS CONSTRUCTION**

Via Parma, 59 – 42028 – POVIGLIO (RE) – ITALY
Tel +39 0522 960050 (r.a.) – Fax +39 0522 960259
e-mail: zapi@zapispa.it – web: www.zapispa.it



User Manual

COMBIAC2

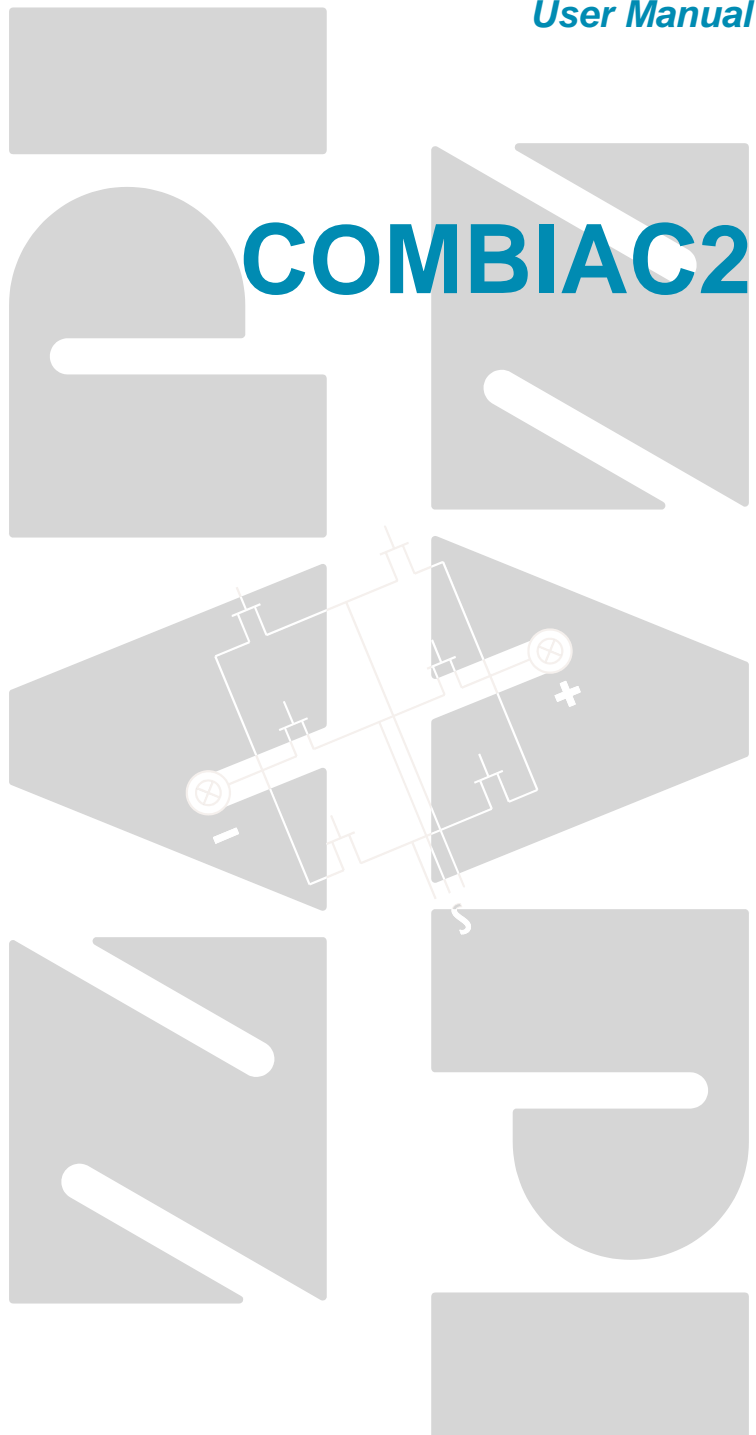

The contents of this publication is a ZAPI S.p.A. property; all related authorizations are covered by Copyright. Any partial or total reproduction is prohibited.

Under no circumstances will Zapi S.p.A. be held responsible to third parties for damage caused by the improper use of the present publication and of the device/devices described in it.

Zapi spa reserves the right to make changes or improvements to its products at any time and without notice.

The present publication reflects the characteristics of the product described at the moment of distribution. The publication therefore does not reflect any changes in the characteristics of the product as a result of updating.



ZAPI® is a registered trademark property of Zapi S.p.A.

NOTES LEGEND



The symbol aboard is used inside this publication to indicate an annotation or a suggestion you should pay attention.



The symbol aboard is used inside this publication to indicate an action or a characteristic very important as for security. Pay special attention to the annotations pointed out with this symbol.

Contents

1	INTRODUCTION	5
2	SPECIFICATION	6
2.1	Technical specifications - "COMBIAC2"	6
2.2	Block diagram - "COMBIAC2"	6
2.3	Technical specifications - "COMBIAC2 Power"	7
2.4	Block diagram - "COMBIAC2 Power"	7
3	SPECIFICATION FOR THE INPUT DEVICES FILLING UP THE INSTALLATION KIT	8
3.1	Microswitches	8
3.2	Analog unit.....	8
3.3	Other analog control unit	9
3.4	Speed feedback.....	10
4	INSTALLATION HINTS.....	11
4.1	Material overview.....	11
4.1.1	Connection cables	11
4.1.2	Contactors.....	11
4.1.3	Fuses	11
4.2	Installation of the hardware.....	11
4.2.1	Positioning and cooling of the controller	12
4.2.2	Wirings: power cables.....	12
4.2.3	Wirings: CAN connections and possible interferences	12
4.2.4	Wirings: I/O connections	15
4.2.5	Encoder installation	15
4.2.6	Main contactor and key connection	16
4.2.7	Insulation of truck frame.....	16
4.3	Protection and safety features	16
4.3.1	Protection features.....	16
4.3.2	Safety Features.....	17
4.4	EMC.....	17
4.5	Various suggestions	19
5	OPERATIONAL FEATURES	20
5.1	Diagnosis	20
6	DESCRIPTION OF THE CONNECTORS.....	22
6.1	Connectors of the logic - "COMBIAC2" e "COMBIAC2 Power"	22
6.2	CANBUS connector description.....	24
6.2.1	"COMBIAC2" Controller in stand-alone configuration.....	24
6.2.2	"COMBIAC2" Controller is a termination module in the canbus net	24
6.2.3	"COMBIAC2" Controller is a repetition module in the canbus net	25
6.3	Description of power connections.....	26
6.3.1	"COMBIAC2".....	26
6.3.2	"COMBIAC2 Power"	27
7	DRAWINGS.....	28
7.1	Mechanical drawing.....	28
7.1.1	Dimensions of "COMBIAC2"	28
7.1.2	Dimensions of "COMBIAC2 Power".....	29
7.2	Connection drawing - "COMBIAC2" and "COMBIAC2 Power" standalone	30
8	PROGRAMMING & ADJUSTMENTS USING DIGITAL CONSOLE	31
8.1	Adjustments via Console	31

8.2	Description of Console & Connection.....	31
8.3	Description of "COMBIAC2" and "COMBIAC2 Power" Standard Console Menu	32
8.3.1	Traction configuration	32
8.3.2	Pump configuration.....	33
8.4	"COMBIAC2" and "COMBIAC2 Power" function configuration.....	34
8.4.1	Traction.....	34
8.4.2	Pump	36
8.5	"COMBIAC2" and "COMBIAC2 Power" parameter regulation.....	42
8.5.1	Traction.....	42
8.5.2	Pump	44
8.6	"COMBIAC2" and "COMBIAC2 Power" programming console functions.....	46
8.7	Sequence for Ac Inverter Traction setting	46
8.8	Sequence for Ac Inverter Pump setting.....	47
8.9	Tester: description of the "COMBIAC2" and "COMBIAC2 Power" function.....	48
8.9.1	Traction.....	48
8.9.2	Pump	48
9	OTHER FUNCTIONS	51
9.1	Save and Restore function	51
9.2	Description of Alarms menu	51
9.3	Description of Console Program Vacc function.....	52
10	"COMBIAC2" INVERTER DIAGNOSTIC	54
10.1	Fault codes.....	54
10.2	Analysis of alarms displayed on console.....	59
11	RECOMMENDED SPARE PARTS FOR INVERTER	63
12	PERIODIC MAINTENANCE TO BE REPEATED AT TIMES INDICATED.....	64

APPROVAL SIGNS

COMPANY FUNCTION	INIZIALS	SIGN
GRAPHIC AND LAYOUT	CP	
PROJECT MANAGER	FG	
TECHNICAL ELECTRONIC MANAGER VISA	PP	
SALES MANAGER VISA	PN	

Publication N°: **AF0ZP0BA**
Edition: **June 2006**

1 INTRODUCTION

Within the ZAPIMOS family, the COMBIAC2 inverter is the model suitable for control of pairs of 3.0 kW to 7.0 kW motors with pump and traction motor functions. These controllers have been expressly designed for battery powered applications, traction and hydraulic functions. They are fit for electric trucks.

2 SPECIFICATION

2.1 Technical specifications - "COMBIAC2"

Inverter for pairs of AC asynchronous 3-phase motors
Regenerative braking functions
Can-bus interface
Flash memory (256 Kbytes On-Chip Program Memory, each microcontroller)
Digital control based upon a microcontroller (one per each motor)
Voltage:..... 24 - 36 - 48 - 72 – 80 V
Maximum current (24 V): 350 A (RMS) for 3' per each motor
Maximum current (36/48 V): 320 A (RMS) for 3' per each motor
Maximum current (72/80 V): 300 A (RMS) for 2' per each motor
Operating frequency: 8 kHz
External temperature range: -30 °C ÷ 40 °C
Maximum inverter temperature (at full power): 75 °C

2.2 Block diagram - "COMBIAC2"

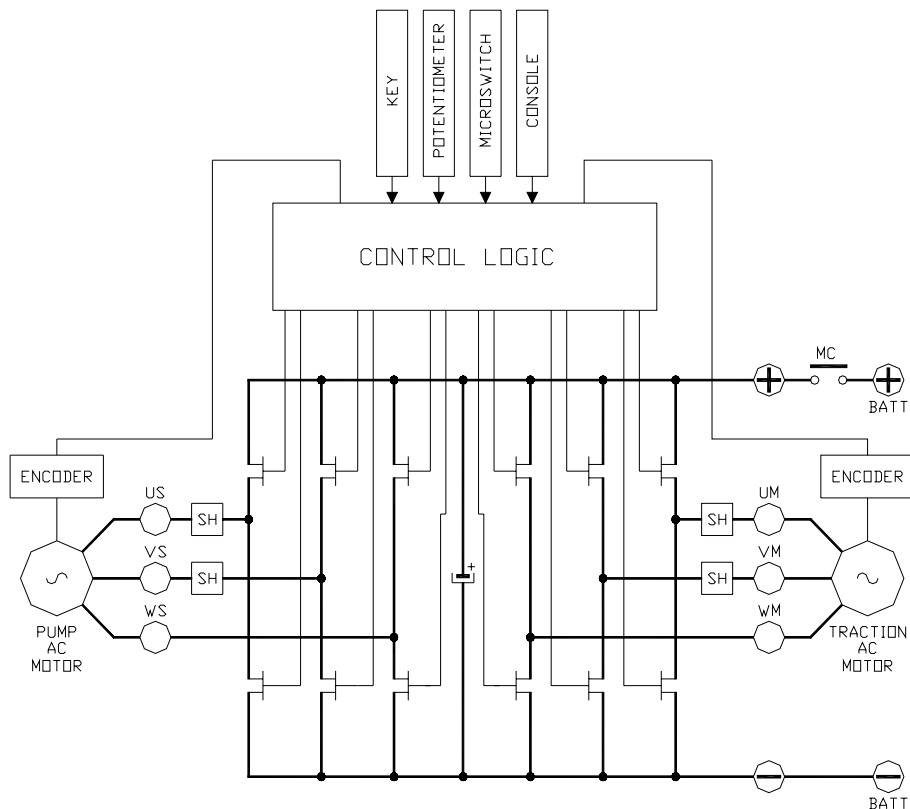

2.3 Technical specifications - "COMBIAC2 Power"

Inverter for pairs of AC asynchronous 3-phase motors

Regenerative braking functions

Can-bus interface

Flash memory (256 Kbytes On-Chip Program Memory, each microcontroller)

Digital control based upon a microcontroller (one per each AC motor)

Voltage:24 - 36 - 48 - 72 – 80 V

Maximum current (24 V):.....500 A (RMS) for 3' per each motor

Maximum current (36/48 V):.....450 A (RMS) for 3' per each motor

Maximum current (72/80 V):.....400 A (RMS) for 2' per each motor

Operating frequency:..... 8 kHz

External temperature range: -30 °C ÷ 40 °C

Maximum inverter temperature (at full power):75 °C

2.4 Block diagram - "COMBIAC2 Power"

See chapter 2.2.

3 SPECIFICATION FOR THE INPUT DEVICES FILLING UP THE INSTALLATION KIT

The COMBIAC2 needs some external parts in order to work. The following devices complete the kit for the COMBIAC2 installation.

3.1 Microswitches

- The microswitches must have a contact resistance lower than 0.1 ohm and a leakage current lower than 100 μ A.
- When full load connected, the voltage drop between the key switch contacts must be lower than 0.1 V.
- The microswitches send a voltage signal to the microprocessor when a function request (for ex.: running request) is made.

3.2 Analog unit

The accelerator, the brake and the lift command unit can consist of a potentiometer or an Hall effect device. It should be in a 3-wire configuration. The accelerator, brake and lift potentiometer are supplied respectively through CNC#33, CNC#33 e CNC#16. It can be either a 5 V output or a 10 V output. The selection of the output voltage is made in the logic card by moving a jumper (factory set).

Accelerator, brake and lift potentiometer output signal must be input respectively to CPOT (CNC#21), CPOTBRK (CNC#18) and CPOTLIFT (CNC#17); signal range is from 0 to 10 V.

The negative supply of the accelerator, brake and lift potentiometer has to be taken respectively from CNC#20, CNC#19 and CNC#15. CNC#20 output (NPOT) is feedback to the μ C A/D converter to test the continuity of the accelerator unit circuit (test of poti wire disconnection).

Potentiometers value should be in the 0.5 - 10 Kohm range; generally, the load should be in the 1.5mA to 30 mA range. Faults can occur if it is outside this range.

The standard connection for the potentiometer is the one in the left side of next figure (potentiometer on one end at rest) in combination with a couple of Travel demand switches. On request it is also possible the handling in the right side of next figure (potentiometer in the middle at rest) still in combination with a couple of Travel demand switches.

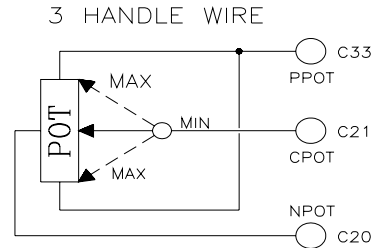
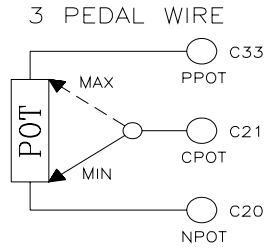

The Procedure for automatic potentiometer signal acquisition is carried out using the Console. This enables adjustment of the minimum and maximum useful signal level (PROGRAM VACC function), in either direction. This function is unique when it is necessary to compensate for asymmetry with the mechanical elements associated with the potentiometer, especially relating to the minimum level. The sequence of procedure is described in the programming console manual.

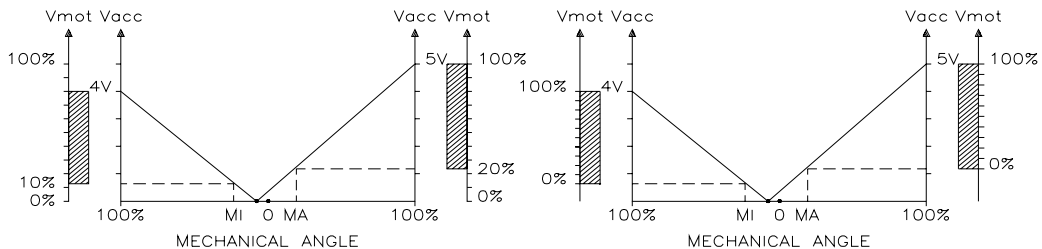

The two graphs show the output voltage from a non-calibrated potentiometer with respect to the mechanical “zero” of the control lever. MI and MA indicate the point where the direction switches close. 0 represents the mechanical zero of the rotation.

The Left Hand graph shows the relationship of the motor voltage without signal acquisition being made. The Right Hand graph shows the same relationship after signal acquisition of the potentiometer.

3.3 Other analog control unit

- 1) Input C18 is an analog input, whose typical application is for proportional braking. It should be in a 3 wire configuration. Potentiometer value should be in the 0.5-10 kohm range. Generally, the load should be in the 1.5 mA to 30 mA range.
The CPOTBRK (C18) signal range is from 0 to 5 V or from 0 V to 10 V.
- 2) Connections C25 (PTHERMR) and C24 (NTHERMR) are used for the traction motor thermal sensor. Connections C35 (PTHERML) and C34 (NTHERML) are used for the pump motor thermal sensor. Sensors can be digital (on/off sensor, normally closed) or analog. See also chapter 8.4 for more explanation.
- 3) Input C17 is an analog input, whose typical application is for lifting. It should be in a 3 wire configuration. Potentiometer value should be in the 0.5-10 kohm range. Generally, the load should be in the 1.5 mA to 30 mA range.
The CPOTLIFT (C17) signal range is from 0 to 5 V or from 0 V to 10 V.

3.4 Speed feedback

The traction motors control is based upon the motor speed feedback. The speed transducer is an incremental encoder, with two phases shifted at 90°. The encoder can be of different types :

- power supply: +5 V or +12 V
- electric output: open collector (NPN or PNP), push-pull

For more details about encoder installation see also chapter 4.2.5.

4 INSTALLATION HINTS

In the description of these installation suggestions you will find some boxes of different colours, they mean:



These are **informations** useful for anyone is working on the installation, or a deeper examination of the content



These are **Warning boxes**, they describe:

- operations that can lead to a failure of the electronic device or can be dangerous or harmful for the operator;
- items which are important to guarantee system performance and safety

4.1 Material overview

Before to start it is necessary to have the required material for a correct installation. Otherwise a wrong choice of cables or other parts could lead to failures/ misbehaviour/ bad performances.

4.1.1 Connection cables

For the auxiliary circuits, use cables of 0.5 mm² section.

For power connections to the motor and to the battery, use cables having section of at least 35 mm².

For the optimum inverter performance, the cables to the battery should be run side by side and be as short as possible.

4.1.2 Contactors

The main contactor must be installed. The LC coil driver is voltage controlled by means of a 1 kHz PWM. The voltage applied to the coil can be adjusted by "Main Cont Voltage" parameter in Config/Adjustment menu. It has to be adjusted to the LC coil nominal voltage.

4.1.3 Fuses

- Use a 6.3 A Fuse for protection of the auxiliary circuits.
- For protection of the power unit, refer to diagrams. The Fuse value shown is the maximum allowable. For special applications or requirements these values can be reduced.
- For Safety reasons, we recommend the use of protected fuses in order to prevent the spread of fused particles should the fuse blow.

4.2 Installation of the hardware



Before doing any operation, ensure that the battery is disconnected and when all the installation is completed start the machine with the drive wheels raised from the floor to ensure that any installation error do not compromise safety.

After operation, even with the Key Switch open, the internal capacitors may remain charged for some time. For safe operation, we recommend that the battery is disconnected, and a short circuit is made between Battery Positive and Battery Negative power terminals of the chopper using a Resistor between 10Ohm and 100Ohm.

4.2.1 Positioning and cooling of the controller

- Install the chopper with the base-plate on a flat metallic surface that is clean and unpainted.
- Apply a light layer of thermo-conductive grease between the two surfaces to permit better heat dissipation.
- Ensure that the wiring of the cable terminals and connectors is carried out correctly.
- Fit transient suppression devices to the horn, solenoid valves, and contactors not connected to the controller.
- The heat generated by the power block must be dissipated. For this to be possible, the compartment must be ventilated and the heat sink materials ample.
- The heat sink material and system should be sized on the performance requirement of the machine. Abnormal ambient air temperatures should be considered. In situations where either ventilation is poor, or heat exchange is difficult, forced air ventilation should be used.
- The thermal energy dissipated by the power block module varies and is dependent on the current drawn and the duty cycle.

4.2.2 Wirings: power cables

- The power cables length must be as short as possible to minimize power losses.
- They must be tightened on controller power posts with a Torque of 13-15 Nm.
- The COMBIAC2 module should only be connected to a traction battery. Do not use converters outputs or power supplies. For special applications please contact the nearest Zapi Service Centre.



Do not connect the controller to a battery with a nominal voltage different than the value indicated on the controller label. A higher battery voltage may cause power section failure. A lower voltage may prevent the logic operating.

4.2.3 Wirings: CAN connections and possible interferences



CAN stands for Controller Area Network. It is a communication protocol for real time control applications. CAN operates at data rate of up to 1 Megabits per second.

It was invented by the German company Bosch to be used in the car industry to permit communication among the various electronic modules of a vehicle, connected as illustrated in this image:

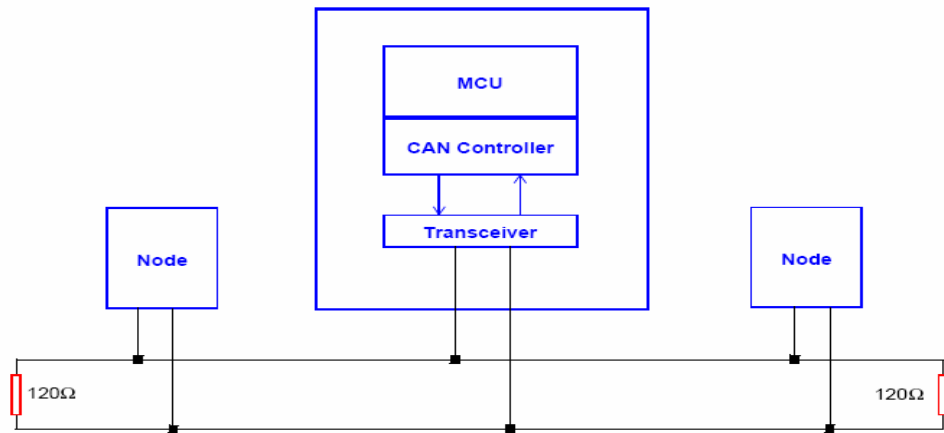

- The best cable for can connections is the twisted pair; if it is necessary to increase the immunity of the system to disturbances, a good choice would be to use a cable with a shield connected to the frame of the truck. Sometimes it is sufficient a simple double wire cable or a duplex cable not shielded.
- In a system like an industrial truck, where power cables carry hundreds of Ampere, there are voltage drops due to the impedance of the cables, and that could cause errors on the data transmitted through the can wires. In the following figures there is an overview of wrong and right layouts of the cables routing.



Wrong Layout:

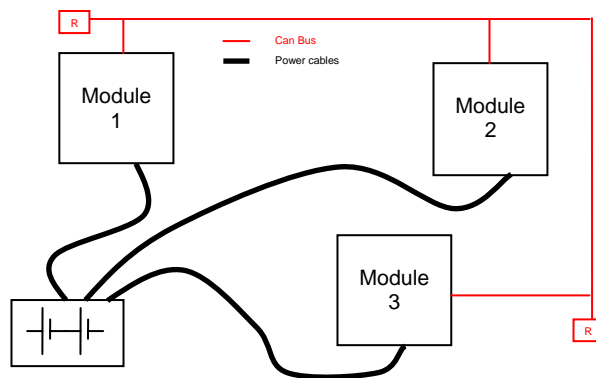

The red lines are can wires.
 The black boxes are different modules, for example traction controller, pump controller and display connected by canbus.
 The black lines are the power cables.

This is apparently a good layout, but can bring to errors in the can line.
 The best solution depends on the type of nodes (modules) connected in the network.
 If the modules are very different in terms of power, then the preferable connection is the daisy chain.



Correct Layout:

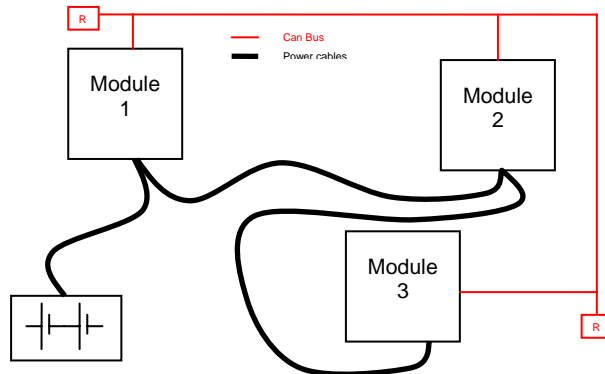

Note: Module 1 power > Module 2 power > Module 3 power

The chain starts from the –BATT post of the controller that works with the highest current, and the others are connected in a decreasing order of power. Otherwise, if two controllers are similar in power (for example a traction and a pump motor controller) and a third module works with less current, the best way to deal this configuration is to create a common ground point (star configuration).



Correct Layout:

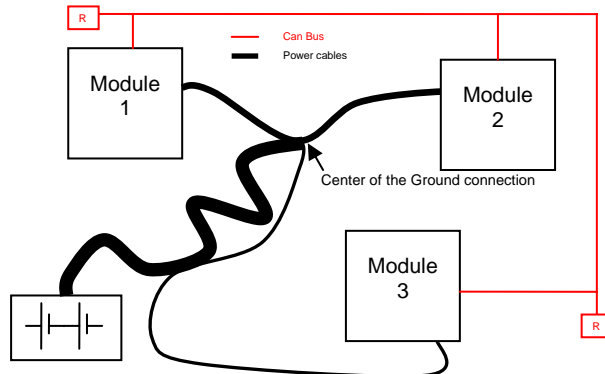

Note: Module 1 power \approx Module 2 power > Module 3 power

In this case the power cables starting from the two similar controllers must be as short as possible. Of course also the diameter of the cable concurs in the voltage drops described before (higher diameter means lower impedance), so in this last example the cable between the minus of the Battery and the common ground point (pointed by the arrow in the image) must be dimensioned taking into account thermal and voltage drop problems.



Can advantages

The complexity of today systems needs more and more data, signal and information must flow from a node to another. CAN is the solution to different problems that arise from this complexity

- simplified design (readily available, multi sourced components and tools)

- lower costs (less and smaller cables)
- improved reliability (fewer connections)
- analysis of problems improved (easy connection with a pc to read the data flowing through the cable).

4.2.4 Wirings: I/O connections

- After crimping the cable, verify that all strands are entrapped in the wire barrel.
- Verify that all the crimped contacts are completely inserted on the connector cavities.



A cable connected to the wrong pin can lead to short circuits and failure; so, before turning on the truck for the first time, verify with a multimeter the continuity between the starting point and the end of a signal wire.

- For information about the mating connector pin assignment see the paragraph “description of the connectors”.

4.2.5 Encoder installation

- 1) Combiac2 card is fit for different types of encoder. To control AC motor with Zapi inverter, it is necessary to install an incremental encoder with 2 phases shifted of 90°. The encoder power supply can be +5 or +12V. It can have different electronic output.

C11/C1	+5V/+12V	positive of encoder power supply.
C12/C2	GND	negative of encoder power supply.
C22/C13	A	phase A of encoder.
C23/C14	B	phase B of encoder.

- 2) Connection of encoder with open collector output; +5V power supply.

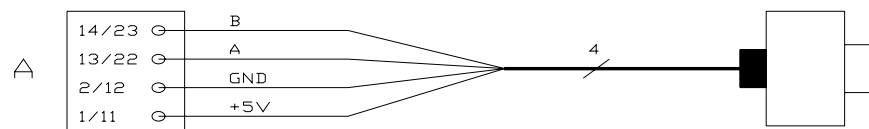

- 3) Connection of encoder with open collector output; +12V power supply.

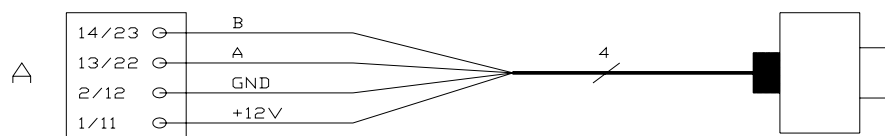

VERY IMPORTANT

It is necessary to specify in the order the type of encoder used, in terms of power supply, electronic output and n° of pulses for revolution, because

the logic unit must be set in the correct way by Zapi.

4.2.6 Main contactor and key connection

- The connection of the main contactor can be carried out following the drawing in the figure.

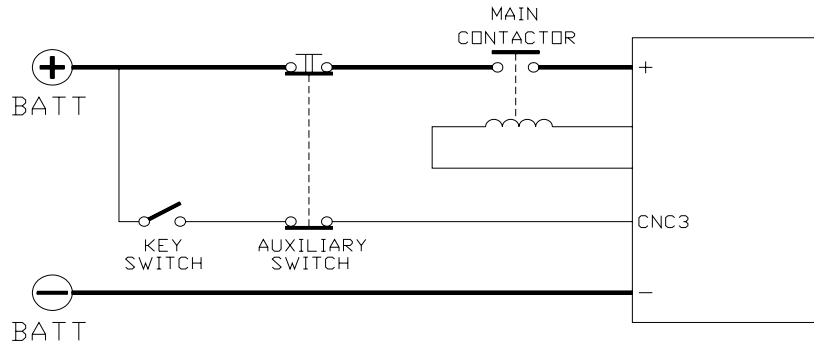

- The connection of the battery line switches must be carried out following ZAPI instructions.
- If a mechanical battery line switch is installed, it is necessary that the key supply to the inverter is open together with power battery line; if not, the inverter may be damaged if the switch is opened during a regenerative braking.
- An intrinsic protection is present inside the logic when the voltage on the battery power connection overtakes 40% more than the battery nominal voltage or if the key is switched off before the battery power line is disconnected.

4.2.7 Insulation of truck frame



As stated by EN-1175 “Safety of machinery – Industrial truck”, chapter 5.7, “there shall be no electrical connection to the truck frame”. So the truck frame has to be isolated from any electrical potential of the truck power line.

4.3 Protection and safety features

4.3.1 Protection features

- **Battery polarity inversion**
It is necessary to fit a MAIN CONTACTOR to protect the inverter against reverse battery polarity and for safety reasons.
- **Connection Errors:**
All inputs are protected against connection errors.
- **Thermal protection**
If the controller temperature exceeds 75 °C, the maximum current is reduced in proportion to the thermal increase. The temperature can never exceed 100 °C.

- **External agents:**
The inverter is protected against dust and the spray of liquid to a degree of protection meeting IP65.
- **Protection against uncontrolled movements:**
The main contactor will not close if:
 - The Power unit is not functioning.
 - The Logic is not functioning perfectly.
 - The output voltage of the accelerator does not fall below the minimum voltage value stored, with 1V added.
 - Running microswitch in closed position.
- **Low battery charge:**
When the battery charge is low, the maximum current is reduced to the half of the maximum current programmed.
- **Protection against accidental Start up**
A precise sequence of operations are necessary before the machine will start.
Operation cannot begin if these operations are not carried out correctly.
Requests for drive, must be made after closing the key switch.

4.3.2 Safety Features



ZAPI controllers are designed according to the prEN954-1 specifications for safety related parts of control system and to UNI EN1175-1 norm.



The safety of the machine is strongly related to installation; length, layout and screening of electrical connections have to be carefully designed. ZAPI is always available to cooperate with the customer in order to evaluate installation and connection solutions. Furthermore, ZAPI is available to develop new SW or HW solutions to improve the safety of the machine, according to customer requirements.
Machine manufacturer holds the responsibility for the truck safety features and related approval.

Combiac2 controller electronic implements double hardware circuit for four Digital inputs: Seat (C5), Forward (C6), Reverse (C7), Accelerator Enable (C8) and one Analog input: CPOT (C21).

These signals are input, through two independent hardware circuits, to both microcontrollers which implement a cross-check of the inputs status, thus preventing an abnormal behaviour due to a failure in the input hardware. It is strongly suggested to connect the machine safety related devices to these five inputs, in order to increase machine safety.

4.4 EMC



EMC and ESD performances of an electronic system are strongly influenced by the installation. Special attention must be given to the lengths and the paths of the electric connections and the shields. This situation is beyond ZAPI's control. Zapi can offer assistance and suggestions, based on its years experience, on EMC related items. However, ZAPI declines any responsibility for non-compliance, malfunctions and failures, if correct testing is not made. The machine

manufacturer holds the responsibility to carry out machine validation, based on existing norms (EN12895 for industrial truck; EN50081-2 for other applications).

EMC stands for Electromagnetic Compatibility, and it represents the studies and the tests on the electromagnetic energy generated or received by an electrical device.

So the analysis works in two directions:

- 1) The study of the **emission** problems, the disturbances generated by the device and the possible countermeasure to prevent the propagation of that energy; we talk about “conduction” issues when guiding structures such as wires and cables are involved, “radiated emissions” issues when it is studied the propagation of electromagnetic energy through the open space. In our case the origin of the disturbances can be found inside the controller with the switching of the mosfets which are working at high frequency and generate RF energy, **but wires and cables have the key role to propagate the disturbs because they works as antennas**, so a good layout of the cables and their shielding can solve the majority of the emission problems.
- 2) The study of the **immunity** can be divided in two main branches: protection from electromagnetic fields and from electrostatic discharge. The **electromagnetic immunity** concern the susceptibility of the controller with regard to electromagnetic fields and their influence on the correct work made by the electronic device. There are well defined tests which the machine has to be exposed to. These tests are carried out at determined levels of electromagnetic fields, to simulate external undesired disturbances and verify the electronic devices response.
- 3) The second type of immunity, **ESD**, concerns the prevention of the effects of electric current due to excessive electric charge stored in an object. In fact, when a charge is created on a material and it remains there, it becomes an “electrostatic charge”; ESD happens when there is a rapid transfer from a charged object to another. This rapid transfer has, in turn, two important effects:
 - A) this rapid charge transfer can determine, by induction, disturbs on the signal wiring and thus create malfunctions; **this effect is particularly critical in modern machines, with serial communications (canbus) which are spread everywhere on the truck and which carry critical informations.**
 - B) in the worst case and when the amount of charge is very high, the discharge process can determine failures in the electronic devices; the type of failure can vary from an intermittently malfunction to a completely failure of the electronic device.

IMPORTANT NOTE: it is always much easier and cheaper to avoid ESD from being generated, than to increase the level of immunity of the electronic devices.

There are different solutions for EMC issues, depending on level of emissions/immunity required, the type of controller, materials and position of the wires and electronic components.

- 1) **EMISSIONS.** Three ways can be followed to reduce the emissions:

- A) **SOURCE OF EMISSIONS:** finding the main source of disturb and work on it.
 - B) **SHIELDING:** enclosing contactor and controller in a shielded box; using shielded cables;
 - C) **LAYOUT:** a good layout of the cables can minimize the antenna effect; cables running nearby the truck frame or in iron channels connected to truck frames is generally a suggested not expensive solution to reduce the emission level.
- 2) **ELECTROMAGNETIC IMMUNITY.** The considerations made for emissions are valid also for immunity. Additionally, further protection can be achieved with ferrite beads and bypass capacitors.
- 3) **ELECTROSTATIC IMMUNITY.** Three ways can be followed to prevent damages from ESD:
- A) **PREVENTION:** when handling ESD-sensitive electronic parts, ensure the operator is grounded; test grounding devices on a daily basis for correct functioning; this precaution is particularly important during controller handling in the storing and installation phase.
 - B) **ISOLATION:** use anti-static containers when transferring ESD-sensitive material.
 - C) **GROUNDING:** when a complete isolation cannot be achieved, a good grounding can divert the discharge current trough a “safe” path; the frame of a truck can works like a “local earth ground”, absorbing excess charge. **So it is strongly suggested to connect to truck frame all the parts of the truck which can be touched by the operator, who is most of the time the source of ESD.**

4.5 Various suggestions

- Never connect SCR low frequency chopper with ASYNCHRONOUS INVERTER because the ASYNCHRONOUS filter capacitors alter the SCR choppers' work. If it is necessary to use two or more control units (traction + lift. for ex.), they must belong to the ZAPIMOS family.
- During battery charge, disconnect ASYNCHRONOUS from the battery.

5 OPERATIONAL FEATURES

- Speed control.
- Optimum behaviour on a slope due to the speed feedback:
 - the motor speed follows the accelerator, starting a regenerative braking if the speed overtakes the speed set-point.
 - the system can perform an electrical stop on a ramp (the machine is electrically hold on a slope) for a programmable time (see also chapter 8.4).
- Stable speed in every position of the accelerator.
- Regenerative release braking based upon deceleration ramps.
- Regenerative braking when the accelerator pedal is partially released (deceleration).
- Direction inversion with regenerative braking based upon deceleration ramp.
- Regenerative braking and direction inversion without contactors: only the main contactor is present.
- The release braking ramp can be modulated by an analog input, so that a proportional brake feature is obtained.
- Optimum sensitivity at low speeds.
- Voltage boost at the start and with overload to obtain more torque (with current control).
- The inverter can drive an electromechanical brake
- Hydraulic steering function:
 - the traction inverter sends a "hydraulic steering function" request to the pump inverter on the can-bus line.
 - moreover, if the pump inverter does not manage the steering function, because it is managed by a motor other than the main hydraulic motor, the traction inverter can manage an "hydraulic steering function" by driving a hydro contactor which drive a hydraulic steering motor (output C31).
- High efficiency of motor and battery due to high frequency commutations.
- Modification of parameters through the programming console.
- Internal hour-meter with values that can be displayed on the console.
- Memory of the last five alarms with relative hour-meter and temperature displayed on the console.
- Diagnostic function with Zapi handset for checking main parameters.
- Built in BDI feature.
- Flash memory, sw downloadable via serial link and via CANBUS.
- Canopen interface available.

5.1 Diagnosis

The microcontrollers continually monitor the inverter and carry out a diagnostic procedure on the main functions. The diagnosis is made in 4 points.

- 1) Diagnosis on key switch closing that checks: watchdog circuit, current sensor, capacitor charging, phase's voltages, contactor drivers, can-bus interface, if the switch sequence for operation is correct and if the output of accelerator unit is correct, correct synchronization of the two μ CS, integrity of safety related inputs hardware.
- 2) Standby diagnosis in stby that checks: watchdog circuit, phase's voltages, contactor driver, current sensor, can-bus interface.
- 3) Diagnosis during operation that checks: watchdog circuits, contactor driver,

current sensors, can-bus interface.

- 4) Continuous diagnosis that checks: temperature of the inverter, motor temperature.

Diagnosis is provided in two ways. The digital console can be used, which gives a detailed information about the failure; the failure code is also sent on the Can-Bus.

6 DESCRIPTION OF THE CONNECTORS

6.1 Connectors of the logic - "COMBIAC2" e "COMBIAC2 Power"

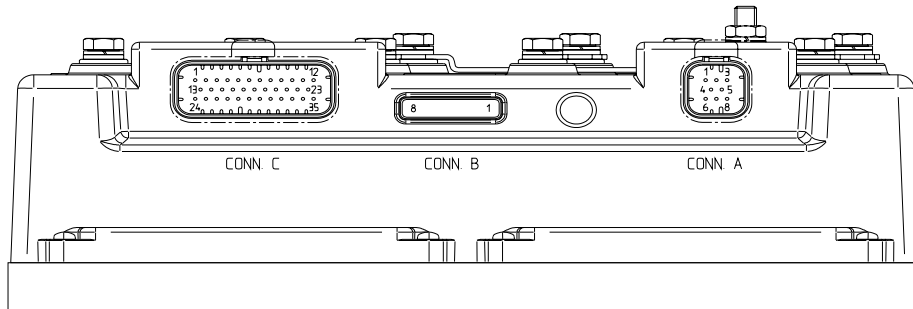

A1	CAN_H	High level CANBUS.
A2	CANT_H	CANBUS termination output, 120 ohm internally connected to CAN_H. Connect to CAN_L_OUT to insert the termination.
A3	CAN_POS	Positive of CAN circuit; to be used in case of optoisolated CANBUS.
A4	CAN_L_OUT	Low level CANBUS: to be used as repetition for CAN_L line or to be connected to CANT_H to insert termination resistance.
A5	CANT_L	CANBUS termination output, 120 ohm internally connected to CAN_L. Connect to CAN_H_OUT to insert the termination.
A6	CAN_L	Low level CANBUS.
A7	CAN_H_OUT	High level CANBUS: to be used as repetition for CAN_H line or to be connected to CANT_L to insert termination resistance.
A8	CAN_NEG	Negative of CAN circuit, to be used in case of optoisolated CANBUS.
B1	PCLRXD	Positive serial reception.
B2	NCLRXD	Negative serial reception.
B3	PCLTXD	Positive serial transmission.
B4	NCLTXD	Negative serial transmission.
B5	GND	Negative console power supply.
B6	+12	Positive console power supply.
B7	FLASH	
B8	FLASH	
C1	PENC_R	Positive of traction motor encoder power supply (+5

		V/+12 V).
C2	NENC_R	Negative of traction motor encoder power supply.
C3	KEY	Connected to +Batt through a microswitch and a 10 A fuse in series.
C4	CM	Common of FW / REV / LIFT ENABLE / PB / SEAT / ENABLE microswitches.
C5	SEAT	Seat presence signal; active high.
C6	FORWARD	Forward direction request signal; active high.
C7	REVERSE	Reverse direction request signal; active high.
C8	ENABLE	Traction request signal; active high.
C9	PB	Pedal brake request signal; active high.
C10	LIFT ENABLE	Lift request signal; active high.
C11	PENC_L	Positive of pump motor encoder power supply (+5 V/+12 V).
C12	NENC_L	Negative of pump motor encoder power supply.
C13	PHA_R	Traction motor encoder phase A.
C14	PHB_R	Traction motor encoder phase B.
C15	NPOTLIFT	Negative of lift potentiometer (-BATT).
C16	PPOTLIFT	Positive of lift potentiometer (+5 V/+12 V).
C17	CPOTLIFT	Lift potentiometer wiper signal.
C18	CPOTB	Brake potentiometer wiper signal.
C19	NPOTB	-BATT.
C20	NPOT	Negative of traction accelerator potentiometer, tested for wire disconnection diagnosis.
C21	CPOT	Traction potentiometer wiper signal.
C22	PHA_L	Pump motor encoder phase A.
C23	PHB_L	Pump motor encoder phase B.
C24	NTHERM_R	Negative of traction motor temperature sensor.
C25	PTHERM_R	Traction motor temperature signal.
C26	NLC	Output of main contactor coil driver (drives to -BATT).
C27	PLC	Positive of main contactor coil.
C28	NBRAKE	Output of electric brake coil; drives the load to -BATT, maximum current 3 A.
C29	PBRAKE	Positive of the electromechanical brake coil.
C30	PAUX	Positive of auxiliary load.
C31	NAUX	Output of auxiliary load driver (drives to -BATT).
C32	-BATT	
C33	PPOT	Traction potentiometer positive, 5/10 V output; use load > 1 kohm.
C34	NTHERM_L	Negative of pump motor temperature sensor.
C35	PTHERM_L	Pump motor temperature signal.

6.2 CANBUS connector description

Combiac2 Controller has a canbus interface, so it has been designed to work in a can network together with other electronic modules, exchanging informations over the canbus network.

Furthermore, the exchange of informations between pump and traction microcontrollers is based on the canbus, as well.

Combiac2 also provides built-in can termination resistance, which can be connected in different ways, as described here following.

6.2.1 "COMBIAC2" Controller in stand-alone configuration

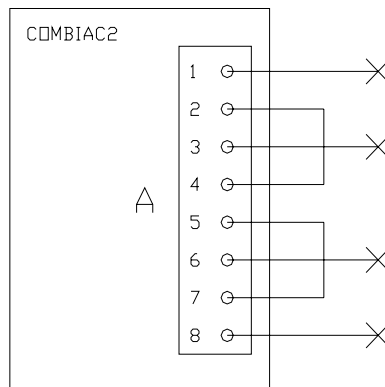

Bridge 2-4 and 5-7 connect both built-in 120 ohm can termination resistances.

6.2.2 "COMBIAC2" Controller is a termination module in the canbus net

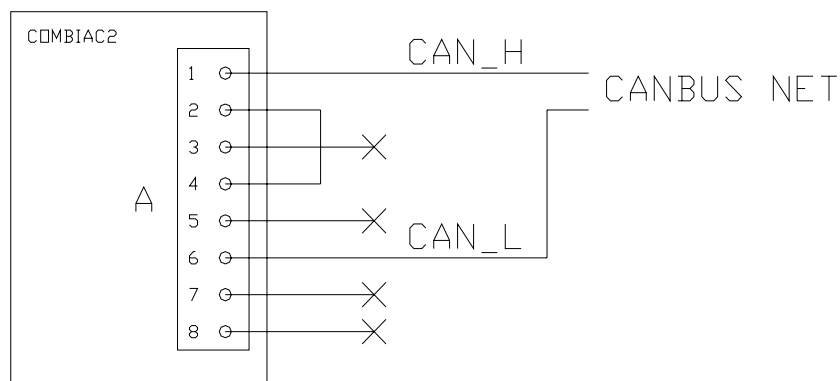

Bridge 2-4 connects one built-in 120 ohm can termination resistance, the second will be connected in another module of the canbus net.

6.2.3 "COMBIAC2" Controller is a repetition module in the canbus net

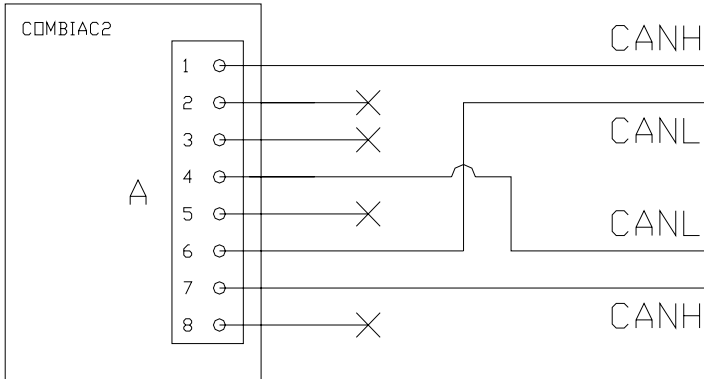

The canbus built-in termination resistances are not inserted.

6.3 Description of power connections

6.3.1 "COMBIAC2"

View of the power bars:

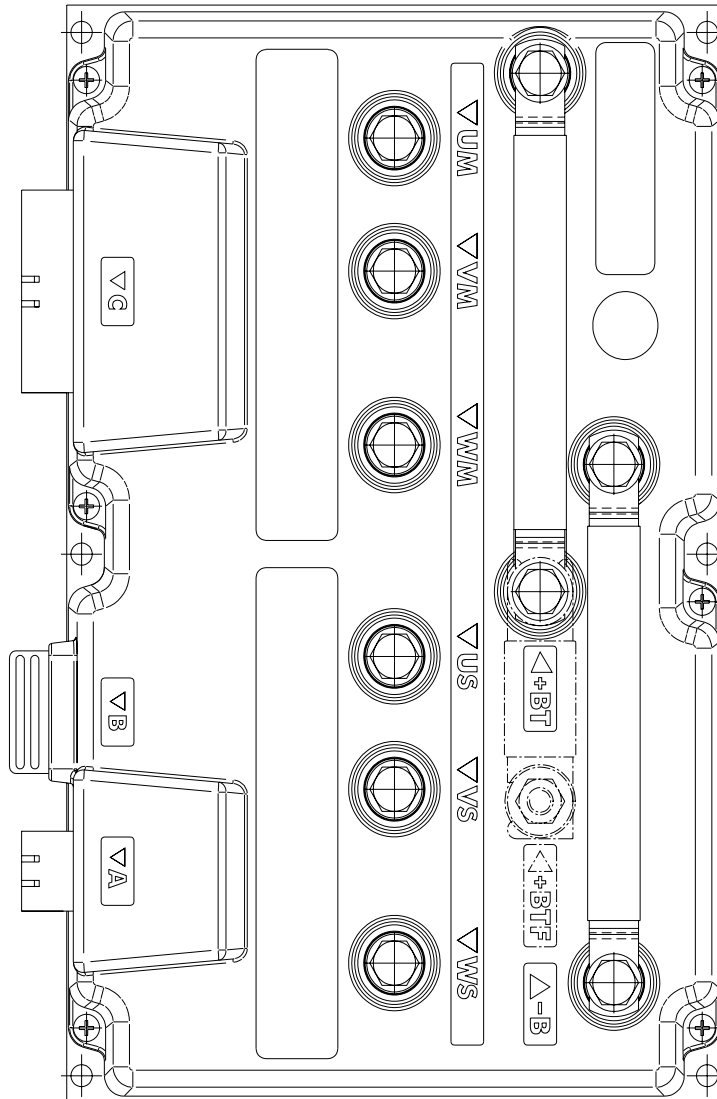

-B	Negative of the battery.
+BT	Positive of the battery; if the power fuse is not present, the positive cable coming from LC contact must be connected to this power connection.
+BTF	Positive of battery before power fuse, must be connected to positive cable coming from LC contact.
Um; Vm; Wm	Connection bars of the three traction motor phases; follow this sequence and the indication on the motor.
Us; Vs; Ws	Connection bars of the three pump motor phases; follow this sequence and the indication on the motor.

6.3.2 "COMBIAC2 Power"

View of the power bars:

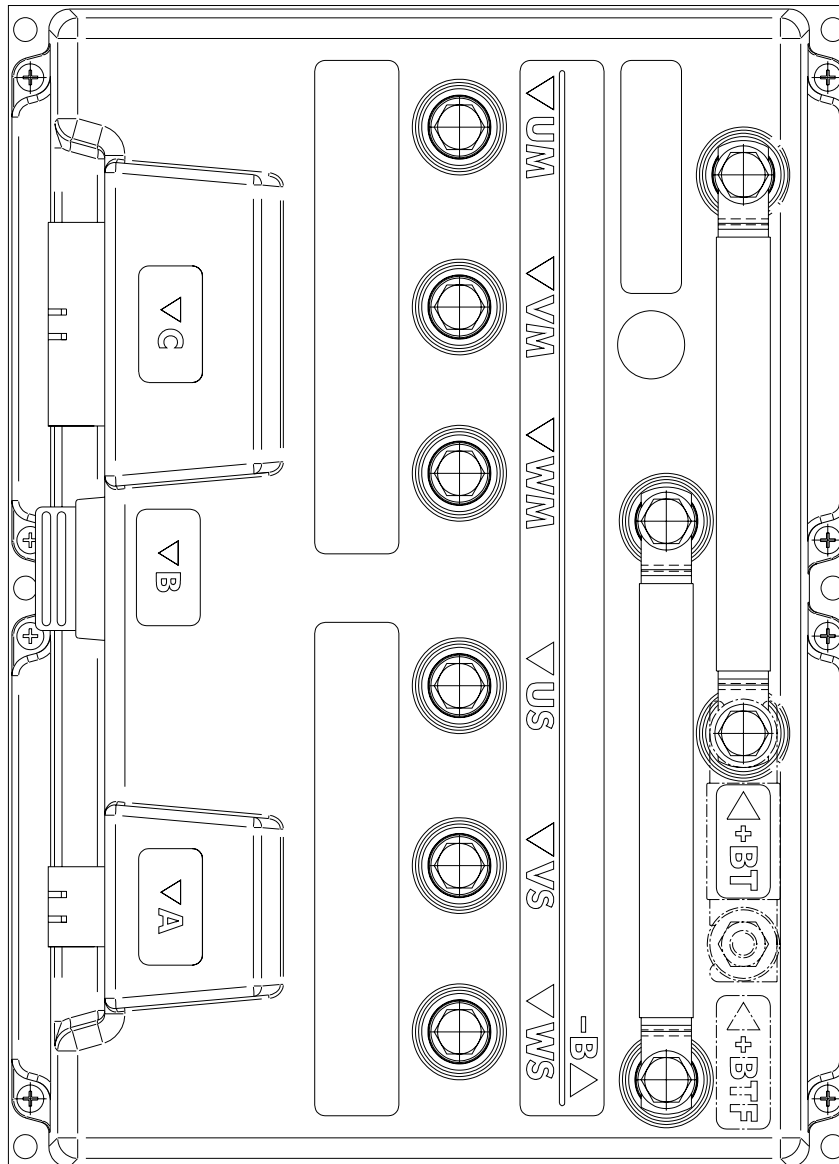

-B	Negative of the battery.
+BT	Positive of the battery; if the power fuse is not present, the positive cable coming from LC contact must be connected to this power connection.
+BTF	Positive of battery before power fuse, must be connected to positive cable coming from LC contact.
Um; Vm; Wm	Connection bars of the three traction motor phases; follow this sequence and the indication on the motor.
Us; Vs; Ws	Connection bars of the three pump motor phases; follow this sequence and the indication on the motor.

7 DRAWINGS

7.1 Mechanical drawing

7.1.1 Dimensions of "COMBIAC2"

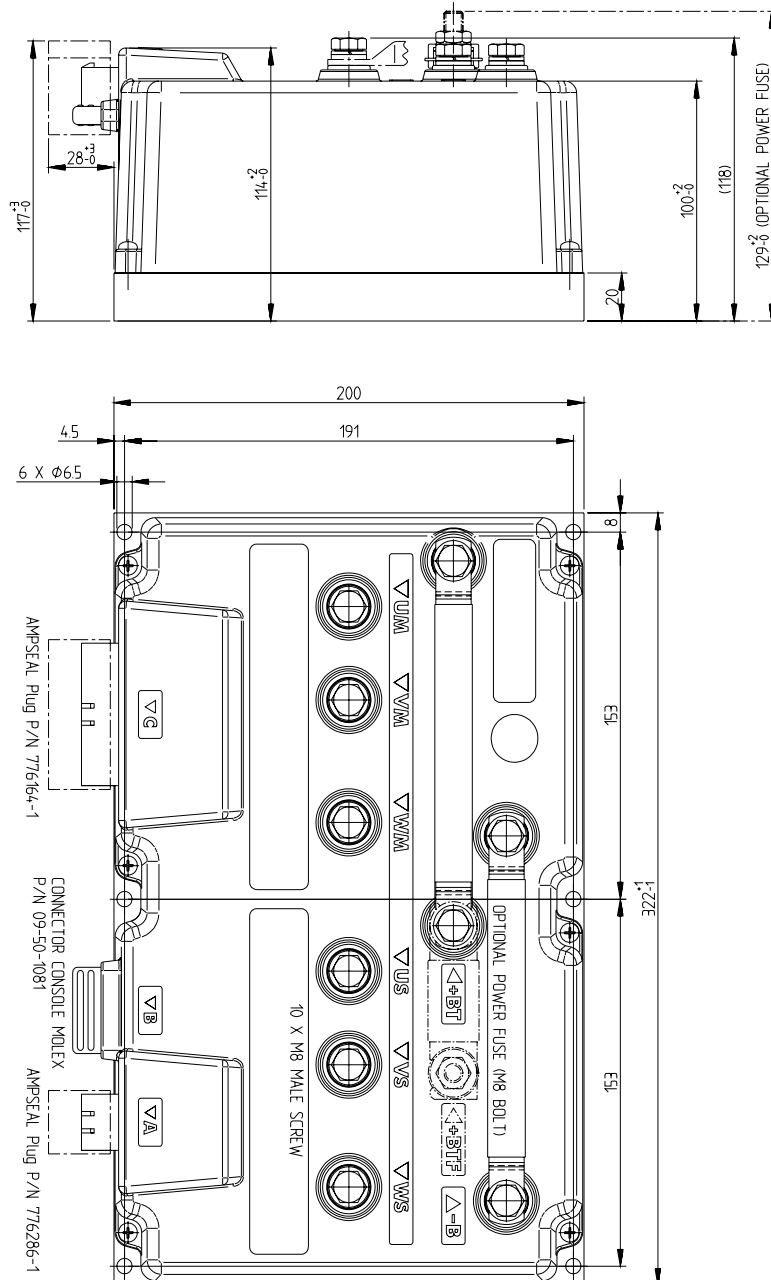

7.1.2 Dimensions of "COMBIAC2 Power"

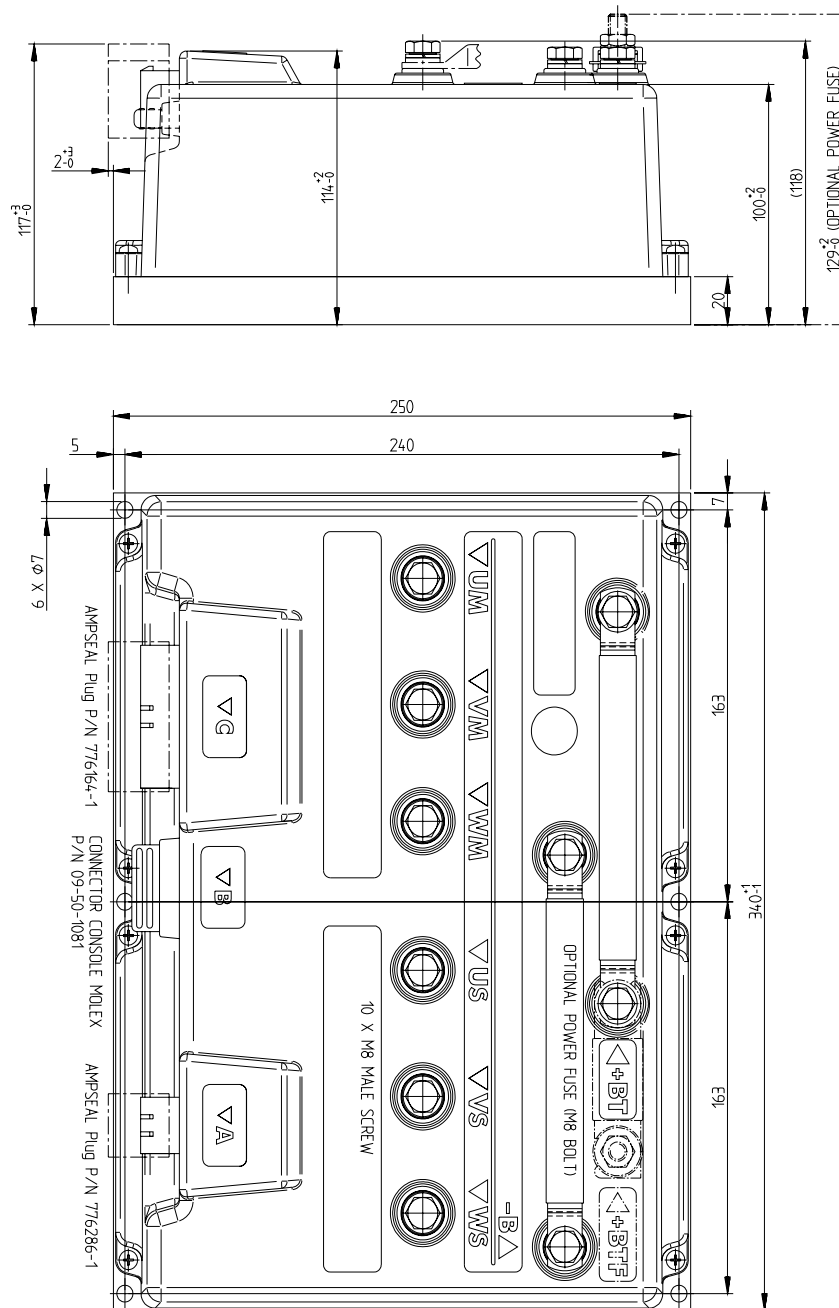

7.2 Connection drawing - "COMBIAC2" and "COMBIAC2 Power" standalone

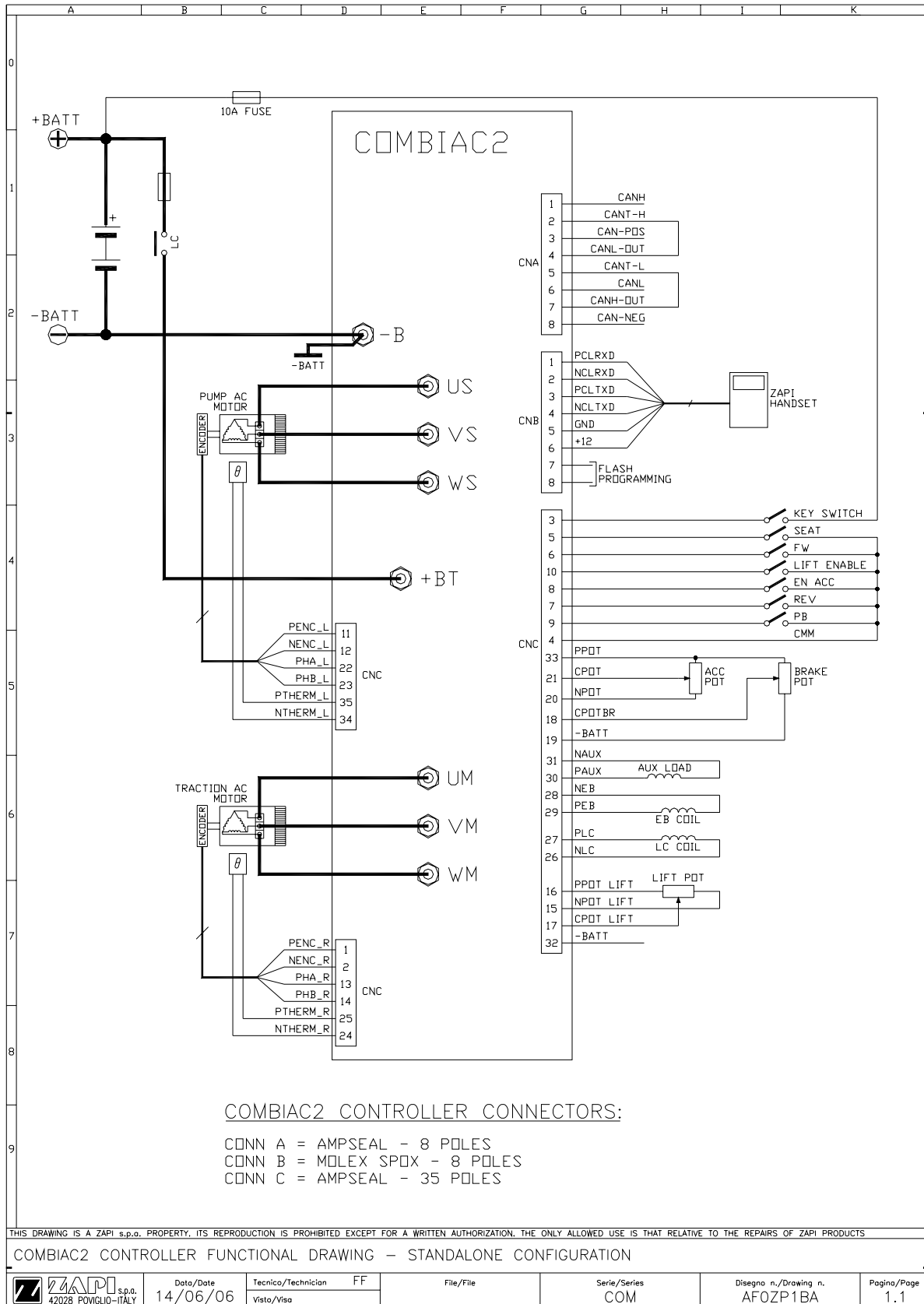

8 PROGRAMMING & ADJUSTMENTS USING DIGITAL CONSOLE

8.1 Adjustments via Console

Adjustment of Parameters and changes to the inverter’s configuration are made using the Digital Console. The Console is connected to the “B” connector of the inverter.

8.2 Description of Console & Connection

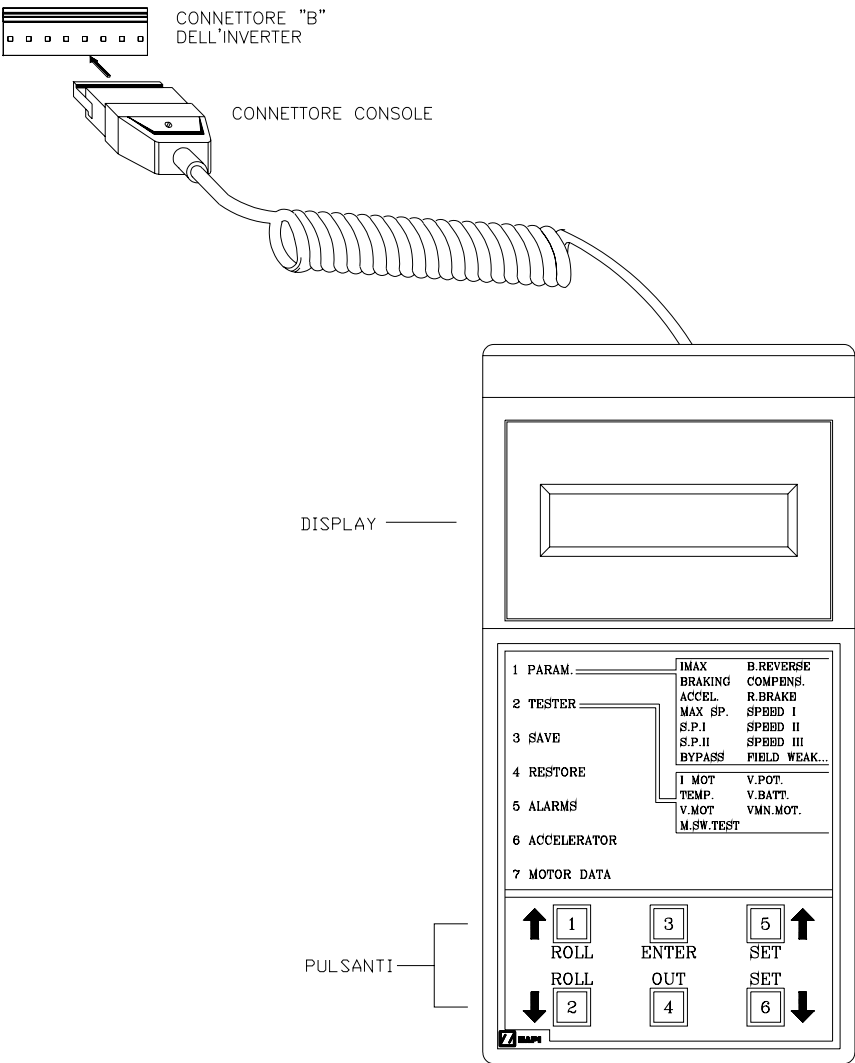

Digital consoles used to communicate with AC inverter controllers must be fitted with EPROM CK ULTRA, minimum "Release Number 3.02".

8.3 Description of "COMBIAC2" and "COMBIAC2 Power" Standard Console Menu

8.3.1 Traction configuration

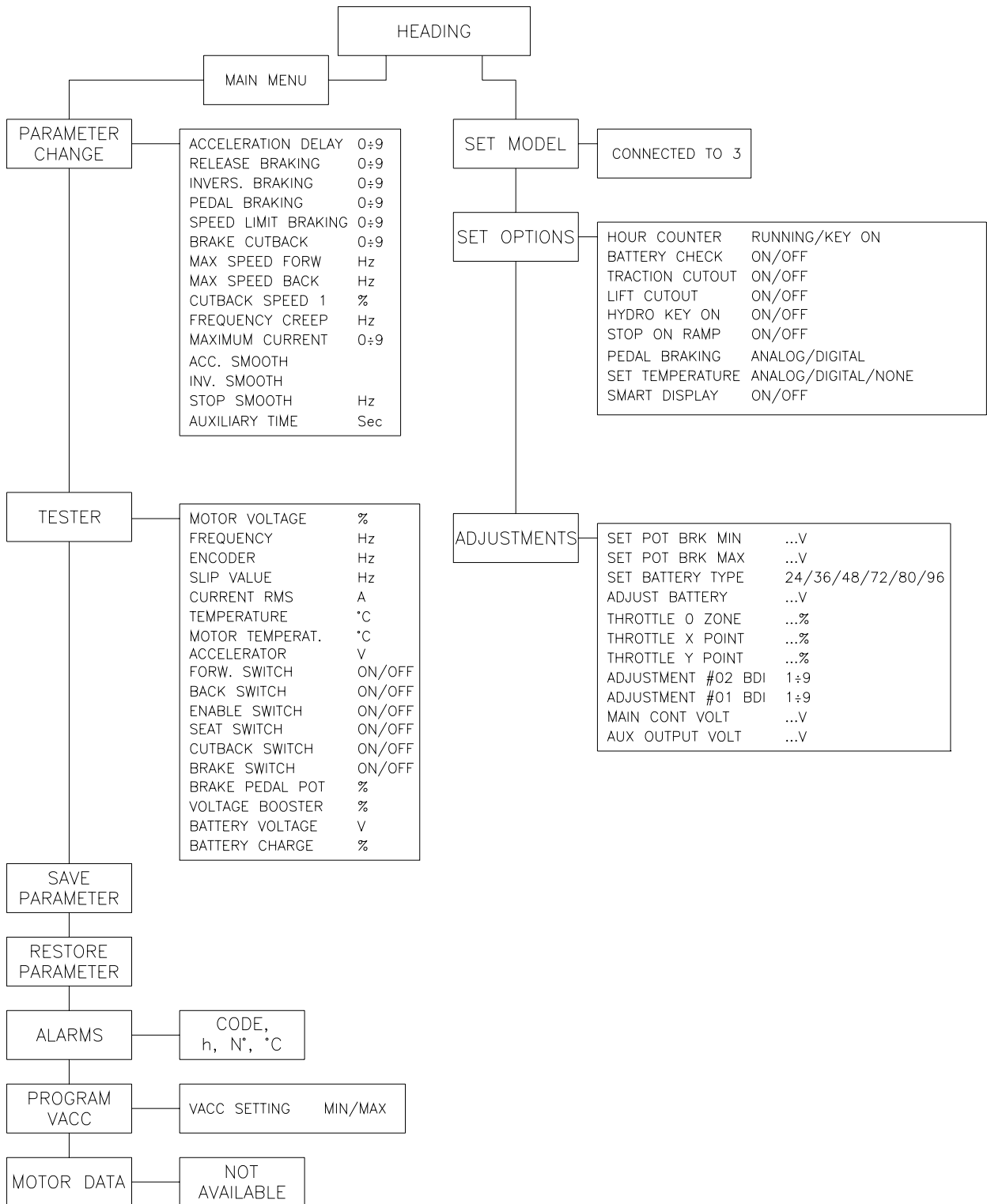

8.3.2 Pump configuration

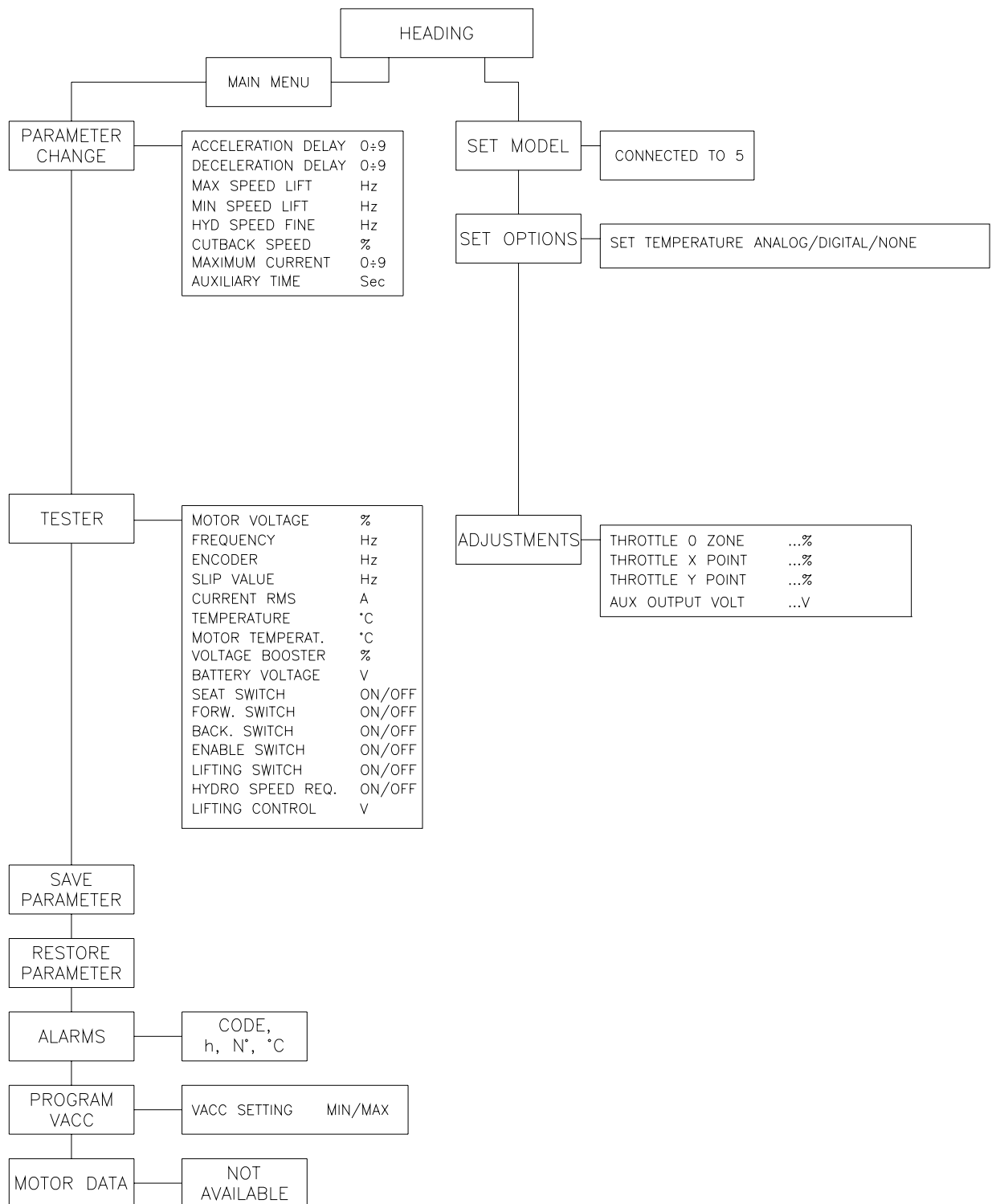

8.4 "COMBIAC2" and "COMBIAC2 Power" function configuration

8.4.1 Traction

Using the CONFIG MENU of the programming console, the user can configure the following functions:

SUBMENU "SET OPTIONS"

1) HOUR COUNTER

- RUNNING: the counter registers travel time only.
- KEY ON: the counter registers when the "key" switch is closed.

2) BATTERY CHECK

- ON: the battery discharge level check is carried out; when the battery level reaches 10%, an alarm is signalled and the maximum current is reduced to the half of the programmed value.
- OFF: the battery discharge level check is carried out but no alarm is signalled.

3) TRACTION CUTOUT

- ON / OFF: when the "Battery low" alarm appears, if this option is programmed ON the traction speed is reduced to 60 Hz.

4) LIFT CUTOUT

- ON / OFF: when the "Battery low" alarm appears, if this option is programmed ON the pump speed is reduced to "Cutback speed" value (see chapter 8.5.2).

5) HYDRO KEY ON

- ON / OFF: if this option is programmed ON the traction inverter manages an hydraulic steering function when the "key" is switched ON.

6) STOP ON RAMP

- ON: the stop on ramp feature (truck electrically hold on a ramp) is managed for a time established by "auxiliary time" parameter.
- OFF: the stop on ramp feature is not performed.

7) PEDAL BRAKING

- ANALOG: the mechanical brake pedal has a switch and a potentiometer installed. When the accelerator is released and the pedal brake is pushed the inverter performs an electrical braking whose intensity is proportional to the brake pedal potentiometer. The minimum intensity is established by the "Release braking" parameter, when the brake pedal is slightly pressed (brake switch close but brake potentiometer at the minimum). The maximum intensity is established by the "Pedal braking" parameter when the brake pedal is fully pressed (brake potentiometer at the maximum). In the middle positions, the electrical braking intensity is a linear function between minimum and maximum intensity.
- DIGITAL: The truck does not have a potentiometer installed on the mechanical brake pedal, but only a microswitch; when the accelerator pedal is released and the brake pedal is pushed (brake switch closed), the inverter performs an electrical braking following "Pedal braking" parameter.

8) SET TEMPERATURE

- DIGITAL: a digital (ON/OFF) motor thermal sensor is connected to C25 input.
- ANALOG: an analog motor thermal sensor is connected to C25 (the curve can be customized on a customer request).
- NONE: no motor thermal sensor switch is connected.

9) SMART DISPLAY

- ON / OFF: if this option is programmed ON the communication with the Smart display is active.

SUBMENU "ADJUSTEMENT"

1) SET POT BRK MIN

It records the minimum value of braking pedal potentiometer when the braking pedal switch is closed; the procedure is similar to the "Program Vacc" function (see chapter 9.3). This procedure must be carried out only if the "Pedal braking" option is programmed as "Analog".

2) SET POT BRK MAX

It records the maximum value of braking pedal potentiometer when the braking pedal is fully pressed; the procedure is similar to the "Program Vacc" function (see chapter 9.3). This procedure must be carried out only if the "Pedal braking" option is programmed as "Analog".

3) SET BATTERY TYPE

It selects the nominal battery voltage.

4) ADJUST BATTERY

Fine adjustment of the battery voltage measured by the controller.

5) THROTTLE 0 ZONE

It establishes a deadband in the accelerator input curve (see also curve below).

6) THROTTLE X POINT

These parameter change the characteristic of the accelerator input curve.

7) THROTTLE Y POINT

These parameter change the characteristic of the accelerator input curve.

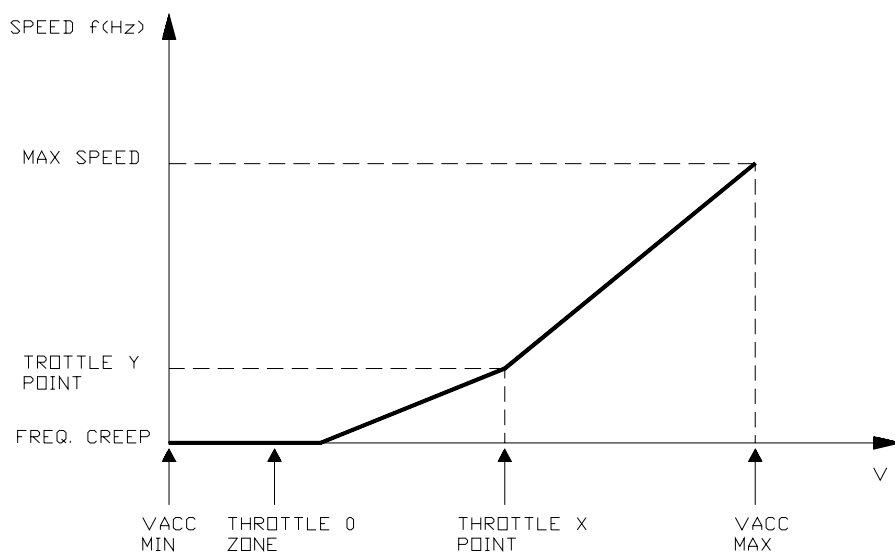

VACC MIN and VACC MAX are values programmable by the "Program Vacc" function.

8) ADJUSTMENT #01 BDI

It adjusts the upper level of the battery discharge table.

9) ADJUSTMENT #02 BDI

It adjusts the lower level of the battery discharge table.

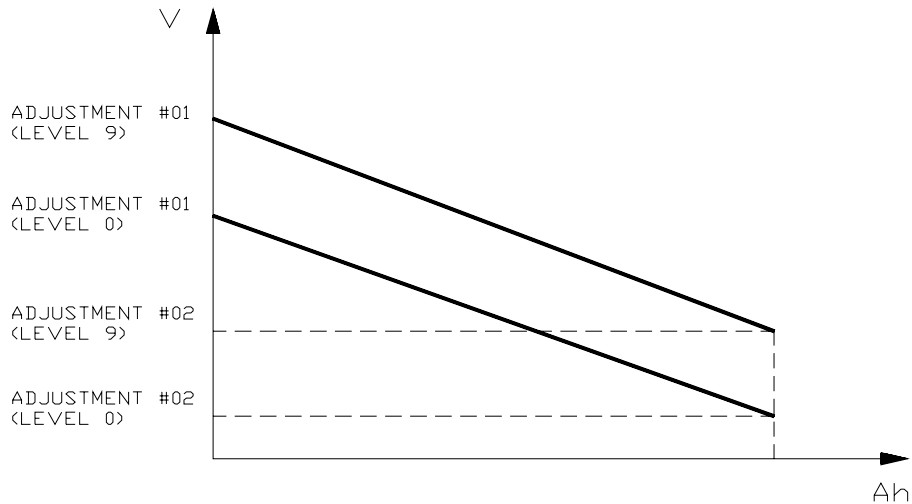

10) MAIN CONT VOLTAGE

This parameter adjusts the Line contactor coil voltage (PWM output C26).

11) AUX OUTPUT VOLTAGE

This parameter adjusts the Electric brake coil voltage (PWM output C28).

8.4.2 Pump

Using the config menu of the programming console, the user can configure the following functions.

SUBMENU "SET OPTIONS"

1) SET TEMPERATURE

- DIGITAL: a digital (ON/OFF) motor thermal sensor is connected to C35 input.
- ANALOG: an analog motor thermal sensor is connected to C35 (the curve can be customized on a customer request).
- NONE: no motor thermal sensor switch is connected.

SUBMENU "ADJUSTEMENT"

1) THROTTLE 0 ZONE

It establishes a deadband in the accelerator input curve (see also curve below).

2) THROTTLE X POINT

These parameter change the characteristic of the accelerator input curve.

3) THROTTLE Y POINT

These parameter change the characteristic of the accelerator input curve.

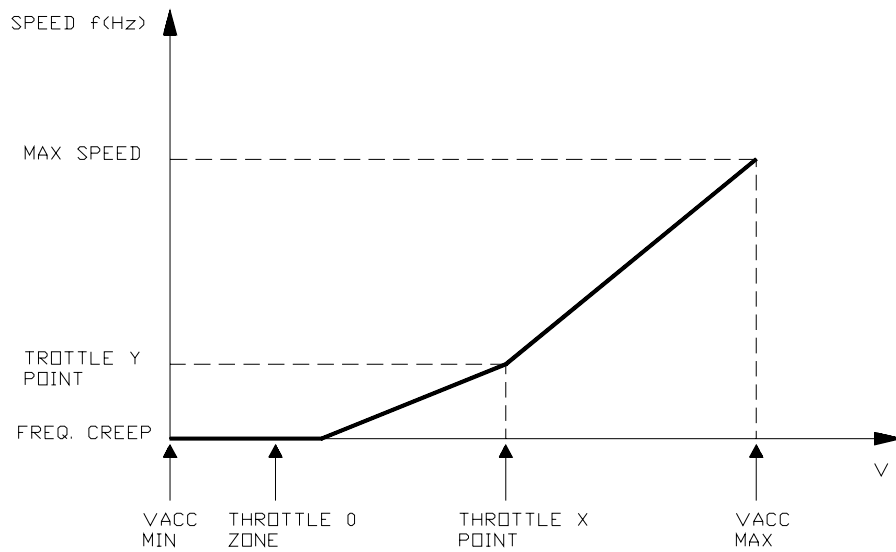

VACC MIN and VACC MAX are values programmable by the "Program Vacc" function.

4) AUX OUPUT VOLTAGE

This parameter adjust the voltage of the auxiliary output coil (hydraulic steering contactor coil), PWM output C31.

Flow chart showing how to make changes to OPTION Menu.

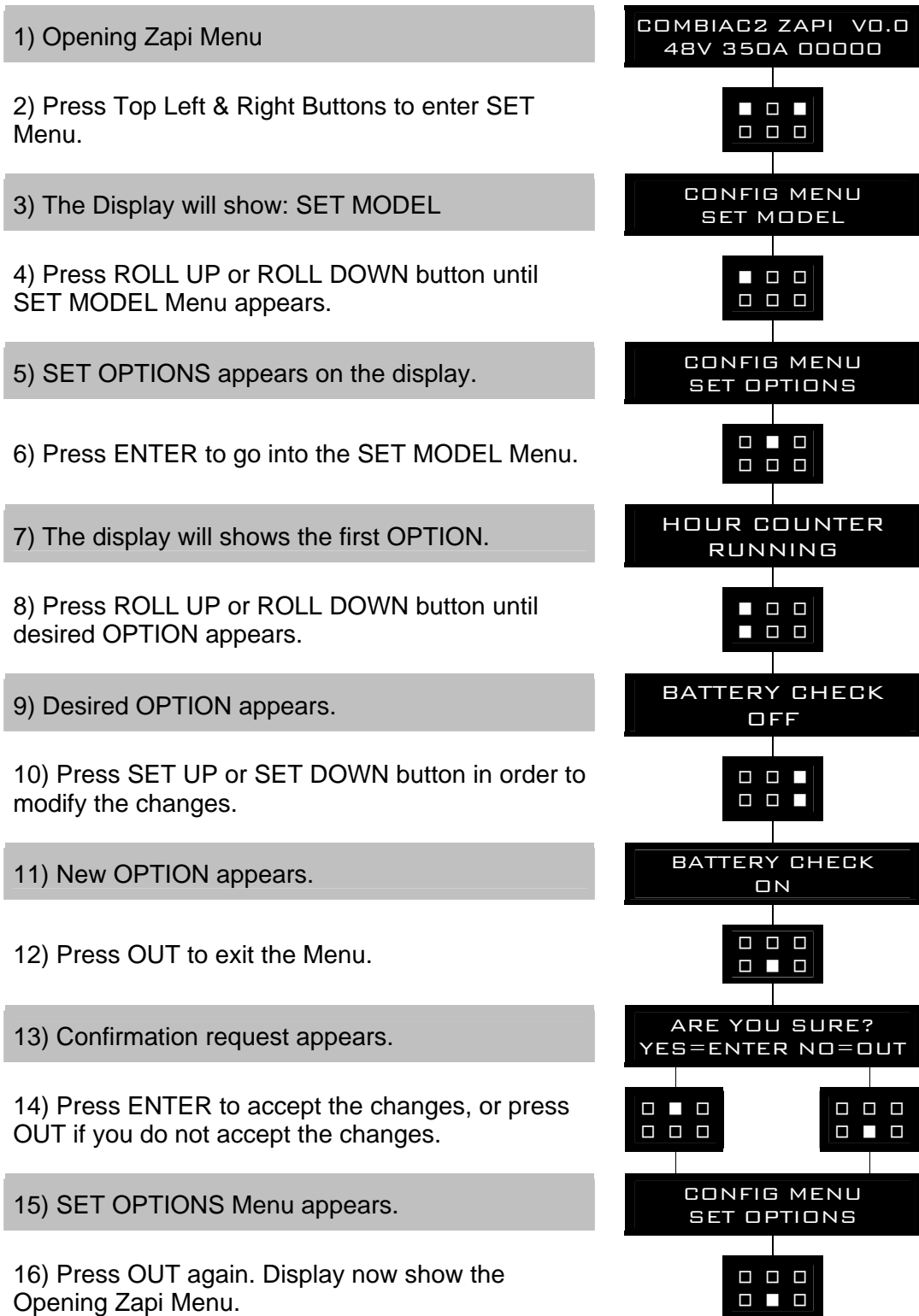

Flow chart showing how to make changes to ADJUSTMENT Menu.

1) Opening Zapi Menu

COMBIAC2 ZAPI V0.0
48V 350A 00000

2) Press Top Left & Right Buttons to enter CONFIG Menu.

■ □ □
□ □ □

3) The display will show: SET MODEL

CONFIG MENU
SET MODEL

4) Press ROLL UP or ROLL DOWN button until ADJUSTMENTS Menu appears.

■ □ □
□ □ □

5) ADJUSTMENTS appears on the display.

CONFIG MENU
ADJUSTMENTS

6) Press ENTER to go into the ADJUSTMENTS Menu.

□ ■ □
□ □ □

7) The display will shows SET BATTERY TYPE.

BATTERY TYPE
48V

8) Press ROLL UP or ROLL DOWN button until the desired parameter is reached.

■ □ □
■ □ □

9) The desired parameter is appears

TROTTLE 0 ZONE
3%

10) Press SET UP or SET DOWN button to modify the adjustment

□ □ ■
□ □ ■

TROTTLE 0 ZONE
7%

11) Press OUT.

□ □ □
□ ■ □

12) Press ENTER to confirm.

□ ■ □
□ □ □

13) Repeat the same from 5 to 12 points for the other adjustment.

Flow chart showing how to use the SET BATTERY TYPE adjustment.

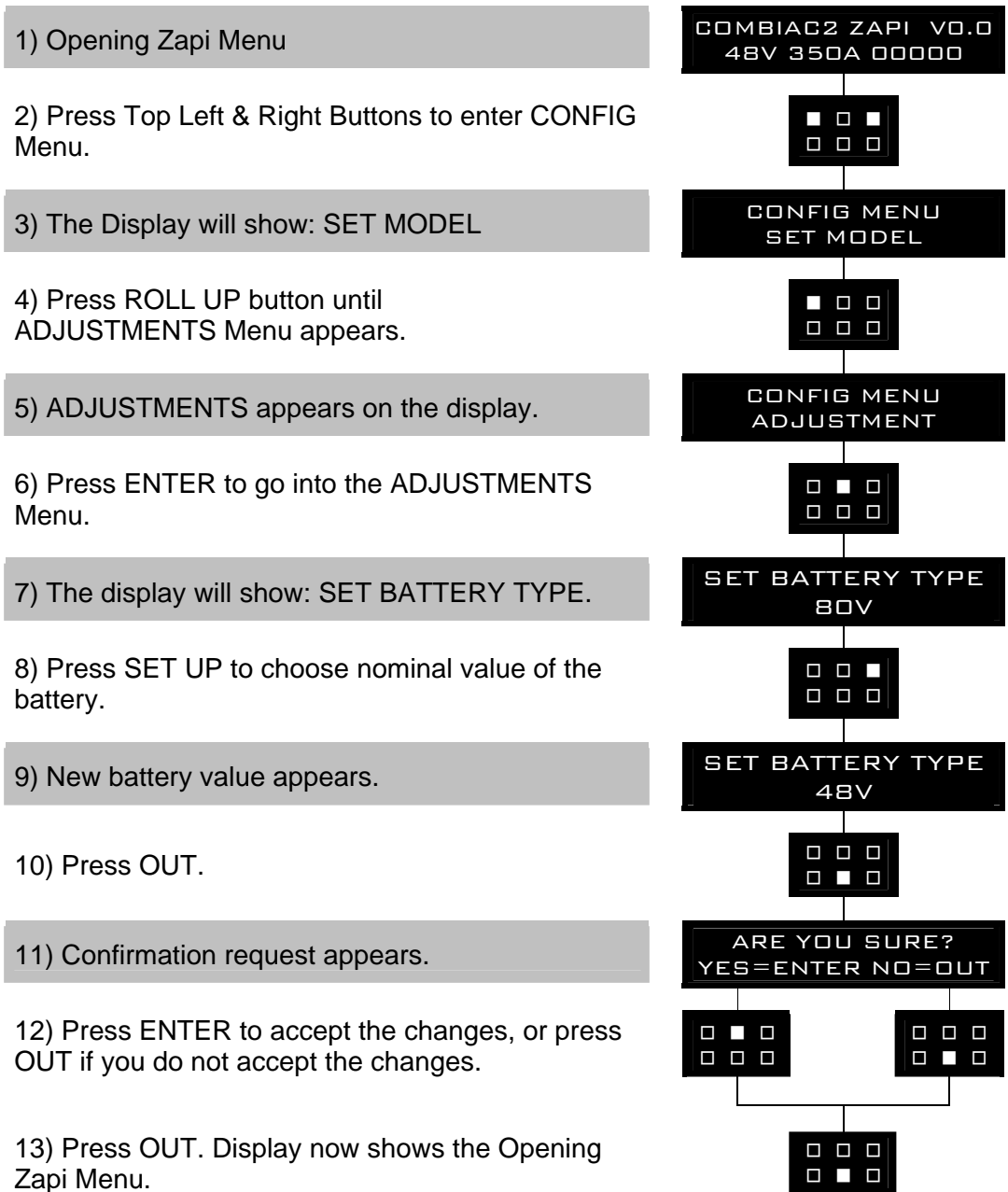

Flow chart showing how to carry out ADJUSTMENT BATTERY operation by console.

1) Opening Zapi Menu

COMBIAC2 ZAPI V0.0
48V 350A 00000

2) Press Top Left & Right Buttons to enter CONFIG Menu.

■ □ □
□ □ □

3) The Display will show: SET MODEL.

CONFIG MENU
SET MODEL

4) Press ROLL UP button until ADJUSTMENT Menu appears.

■ □ □
□ □ □

5) ADJUSTMENTS appears on the display.

CONFIG MENU
ADJUSTMENT

6) Press ENTER to go into the ADJUSTMENTS Menu.

□ ■ □
□ □ □

7) The display will show the first OPTION.

SET POT BRK MIN
0.0V

8) Press ROLL UP or ROLL DOWN button until desired OPTION appears.

■ □ □
■ □ □

9) ADJUST BATTERY appears.

ADJUSTMENT BATTERY
82.1V

10) Press SET UP or SET DOWN button in order to increase or decrease respectively. Set the value read by an external voltmeter.

□ □ ■
□ □ ■

11) Battery value appears on the display.

ADJUSTMENT BATTERY
84.5V

12) Press OUT to exit the Menu.

□ □ □
□ ■ □

13) Confirmation request appears.

ARE YOU SURE?
YES=ENTER NO=OUT

14) Press ENTER to accept the changes, or press OUT if you do not accept the changes.

□ ■ □ □ □ □
□ □ □ □ ■ □

15) ADJUSTMENTS Menu appears.

CONFIG MENU
ADJUSTMENT

16) Press OUT. Display now show the Opening Zapi Menu.

□ □ □
□ ■ □

8.5 "COMBIAC2" and "COMBIAC2 Power" parameter regulation

8.5.1 Traction

The following parameters can be modified:

- 1) **ACC DELAY**
It determines the acceleration ramp.
- 2) **RELEASE BRAKING**
It controls the deceleration ramp when the travel request is released.
- 3) **INVERSION BRAKING**
It controls the deceleration ramp when the direction switch is inverted during travel.
- 4) **PEDAL BRAKING**
It determines the deceleration ramp when the travel request is released and the brake pedal switch is closed.
- 5) **SPEED LIMIT BRAKING**
Deceleration ramp when the pedal position is changed but not completely released.
- 6) **BRAKE CUTBACK**
It determines the deceleration ramp when the speed reduction input becomes active and the motor slow down.
- 7) **MAX SPEED FORWARD**
It determines the maximum speed in forward direction.
- 8) **MAX SPEED BACKWARD**
It determines the maximum speed in backward direction.
- 9) **CUTBACK SPEED 1**
Not used.
- 10) **FREQUENCY CREEP**
Minimum speed when the forward or reverse switch is closed, but the accelerator is on a minimum position.
- 11) **MAXIMUM CURRENT**
This changes the maximum current of the inverter.
- 12) **ACC. SMOOTH**
It gives a different form to the acceleration curve in the frequency range 0 Hz to "Stop smooth" value (see the figure below).
- 13) **INV. SMOOTH**
It gives a different form to the acceleration curve after a direction inversion in the frequency range 0 Hz to "Stop smooth" value (see the figure below).
- 14) **STOP SMOOTH**
It sets the level of frequency where the smooth effect on the acceleration ramp ends.

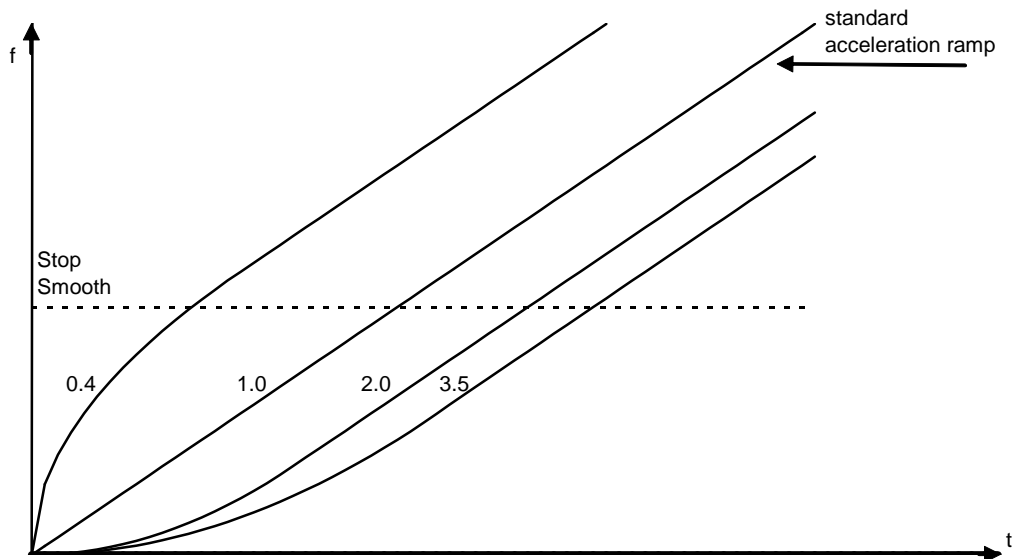

0.4, 1.0, 2.0, 3.5 are some possible values of the “Acc. Smooth” and “Inv. Smooth” parameters (see the table below).

15) AUXILIARY TIME

It determines the time that the truck is hold on the ramp if the "stop on ramp" option is ON.

The following table shows the different values at which the parameters can be set.

PARAMETER	UNIT	PROGRAMMED LEVEL									
		0	1	2	3	4	5	6	7	8	9
ACCELERATION DELAY (*)	Sec.	1.0	1.5	2.0	2.5	3.0	3.5	4.0	4.5	5.0	5.5
RELEASE BRAKING (**)	Sec.	5.5	5.0	4.5	4.0	3.5	3.0	2.5	2.0	1.5	1.0
INVERSION BRAKING (**)	Sec.	5.5	5.0	4.5	4.0	3.5	3.0	2.5	2.0	1.5	1.0
PEDAL BRAKING (**)	Sec.	5.5	5.0	4.5	4.0	3.5	3.0	2.5	2.0	1.5	1.0
SPEED LIMIT BRAKING (**)	Sec.	8.9	8.3	7.7	7.1	6.6	6.0	5.5	4.9	4.4	3.8
BRAKE CUTBACK (**)	Sec.	5.5	5.0	4.5	4.0	3.5	3.0	2.5	2.0	1.5	1.0
MAX SPEED FW	Hz	65	80	95	110	125	140	155	170	185	200
MAX SPEED BW	Hz	65	80	95	110	125	140	155	170	185	200
FREQUENCY CREEP	Hz	0.3	0.6	0.9	1.2	1.5	1.8	2.1	2.4	2.7	3.0
MAXIMUM CURRENT	%IMAX	43	50	56	62	68	75	81	87	94	100
ACC. SMOOTH		1.0	1.2	1.5	1.7	2.0	2.2	2.5	2.7	3.0	3.5
INV. SMOOTH		0.4	0.6	0.8	1.0	1.2	1.5	1.7	2.0	2.5	3.0
STOP SMOOTH	Hz	5	7	10	12	15	17	20	22	25	27
AUXILIARY TIME	Sec.	0	0.2	0.4	0.8	1	1.5	2	3	4	5

(*) The acceleration time shown is the time from 0 Hz to 100 Hz. This is the ideal ramp calculated by the software; the real ramp could change as a function of motor control parameter setting and, obviously, as a function of the load.

(**) The braking feature is based upon deceleration ramps. The value shown in the table is the time to decrease the speed from 100 Hz to 0 Hz. This

is the ideal ramps calculated by the software; the real ramp could change as a function of motor control parameter setting and, obviously, as a function of the load.

8.5.2 Pump

The following parameters can be modified:

- 1) **ACC DELAY**
It determines the acceleration ramp.
- 2) **DEC. DEALY**
It determines the deceleration ramp.
- 3) **MAX SPEED LIFT**
It determines the maximum lifting speed.
- 4) **MIN SPEED LIFT**
Minimum speed when the lift enable switch is closed, but the lift potentiometer is on a minimum position.
- 5) **HYD SPEED FINE**
Hydraulic steering speed, fine regulation.
- 6) **CUTBACK SPEED**
Speed reduction when the cutback switch is active.
- 7) **MAXIMUM CURRENT**
This changes the maximum current of the inverter.
- 8) **AUXILIARY TIME**
Time delay when an hydraulic steering function request is switched off.

The following table shows the different values at which the parameters can be set.

PARAMETER	UNIT	PROGRAMMED LEVEL									
		0	1	2	3	4	5	6	7	8	9
ACCELERATION DELAY (*)	Sec.	1.0	1.2	1.4	1.6	1.8	2.0	2.5	3.3	4.5	6.0
DECELERATION DELAY	Sec.	1.0	1.2	1.4	1.6	1.8	2.0	2.5	3.3	4.5	6.0
MAX SPEED LIFT	Hz	6 - 200									
MIN SPEED LIFT	Hz	12.0	13.5	15.0	16.5	18.0	19.5	21.0	22.5	24.0	25.5
HYD SPEED FINE	Hz	0 - 50									
CUTBACK SPEED	%Max Sp	50	54	58	62	66	70	74	78	82	88
MAXIMUM CURRENT	%IMAX	43	50	56	62	68	75	81	87	94	100
AUXILIARY TIME	Sec.	0	0.2	0.4	0.8	1	1.5	2	3	4	5

(*) The acceleration time shown is the time from 0 Hz to 100 Hz. This is the ideal ramp calculated by the software; the real ramp could change as a function of motor control parameter setting and, obviously, as a function of the load.

(**) The braking feature is based upon deceleration ramps. The value shown in the table is the time to decrease the speed from 100 Hz to 0 Hz. This is the ideal ramps calculated by the software; the real ramp could change as a function of motor control parameter setting and, obviously, as a function of the load.

After changing a parameter, press ENTER to confirm data when requested by the message on the console. Parameters modified and optimized on one unit can be stored by the Zapi Pc-console (SAVE) and then downloaded (RESTORE) to another controller, thus allowing fast and standardized settings (see Pc-console manual for details).

Flow Chart showing how to make Parameter changes using Digital Console fitted with Eprom CK ULTRA.

1) Opening Zapi Display.

COMBIAC2 ZAPI V0.0
48V 350A 00000

2) Press ENTER to go into the General Menu.

□ ■ □
□ □ □

3) The Display will show:

MAIN MENU
PARAMETER CHANGE

4) Press ENTER to go into the Parameter Change facility.

□ ■ □
□ □ □

5) The Display will show the first parameter.

ACCEL. DELAY
LEVEL = 4

6) Press either ROLL UP and ROLL DOWN to display the next parameter.

■ □ □
■ □ □

7) The names of the Parameters appear on the Display.

RELEASE BRAKING
LEVEL = 5

8) When the desired Parameter appears, the Display will show a Level Number that will be Between 0 and 9. Press either PARAM (Top Right) or SET (Bottom Right) buttons to change the Level value.

□ □ ■
□ □ ■

9) The Display will show the New Level.

RELEASE BRAKING
LEVEL = 6

10) When you are satisfied with the results of the changes you have made, Press OUT.

□ □ □
□ ■ □

11) The Display asks "ARE YOU SURE?".

ARE YOU SURE?
YES=ENTER NO=OUT

12) Press ENTER to accept the changes, or press OUT if you do not wish to accept the changes and wish to make further modifications to the parameters.

□ ■ □ □ □ □
□ □ □ □ ■ □

13) The Display will show:

MAIN MENU
PARAMETER CHANGE

8.6 "COMBIAC2" and "COMBIAC2 Power" programming console functions

- Functional configuration (see 8.4).
- Parameter programming (see 8.5).
- Tester: user can verify the state of the following parameters:

TRACTION	PUMP
motor voltage (%)	motor voltage (%)
frequency (Hz)	frequency (Hz)
encoder (Hz)	encoder (Hz)
slip value (Hz)	slip value (Hz)
current rms (A)	current rms (A)
temperature (°C)	temperature (°C)
motor temperat. (°C)	motor temperat. (°C)
accelerator (V)	voltage booster (%)
forw. switch (ON/OFF)	battery voltage (V)
back. switch (ON/OFF)	seat switch (ON/OFF)
enable switch (ON/OFF)	forw. switch (ON/OFF)
seat switch (ON/OFF)	back. switch (ON/OFF)
cutback switch (ON/OFF)	enable switch (ON/OFF)
brake switch (ON/OFF)	lifting switch (ON/OFF)
brake pedal pot (%)	hydro speed req. (ON/OFF)
voltage booster (%)	lifting control (V)
battery voltage (V)	
battery charge (%)	
- Save function (for storing data) --> only with Pc-console.
- Restore function (for downloading parameters to another controller) --> only with Pc-console.
- Display of the last 5 alarms including hour-meter value and temperature at the moment of the alarm.
- Accelerator range programming.
Records the minimum and maximum useful accelerator stroke values for both direction of running.
- See the console manual for a detailed description of function and parameters.

8.7 Sequence for Ac Inverter Traction setting

When the "Key Switch" is closed, if no alarms or errors are present, the Console Display will be showing the Standard Zapi Opening Display.

If the controller is not configured to your requirements, follow the sequence detailed here following. Remember to re-cycle the Key Switch if you make any changes to the controller's configuration.

- 1) Select the Options required. See Chapter 8.4.1.
- 2) Select and set the Battery Voltage. See Chapter 8.4.1.
- 3) Confirm correct installation of all wires. Use the Console's TESTER function to assist.
- 4) Perform the accelerator signal acquisition procedure using the Console "PROGRAM VACC". Procedure is detailed on Chapter 9.3.
- 5) Perform the steering potentiometer signal acquisition, using the parameters in "Adjustment" menu (see Chapter 8.4.1).
Remember: turning the wheel to right direction, voltage has to increase.

- 6) Set the maximum steering angles, right and left direction; use the parameters in "Adjustment" menu (see Chapter 8.4.1).
- 7) Set the "MAXIMUM CURRENT" Current, using the table on Chapter 8.5.1.
- 8) Set the Acceleration Delay requirements for the machine. Test the parameter setting in both directions.
- 9) Set the FREQUENCY CREEP level starting from level 0.6 Hz. The machine should just move when the accelerator microswitch is closed. Increase the Level accordingly.
- 10) Set the Speed Reductions as required. Make adjustments to "CUTBACK SPEED". Check the performance with the accelerator pedal totally depressed. If the machine is a forklift, check the performance with and without load.
- 11) RELEASE BRAKING. Operate the machine at full speed. Release the accelerator pedal. Adjust the level to your requirements. If the machine is a forklift, check the performance with and without load.
- 12) INVERSION BRAKING. Operate the machine at 25% full speed. Whilst traveling INVERT the Direction Switch. Set a soft Level of Inversion Braking. When satisfactory, operate the machine at Full Speed and repeat. If the machine is a Forklift, repeat the tests and make adjustments with and without load. The unladen full speed condition should be the most representative condition.
- 13) PEDAL BRAKING (If used). Operate the machine at full Speed. Release the accelerator pedal and press the Pedal Brake. Set braking level to your requirements.
- 14) Set "MAX SPEED FORW".
- 15) Set "MAX SPEED BACK" (Reverse).
- 16) Make the choice for the truck behaviour on a slope (see chapter 8.4.1). If the "Stop on ramp" option is ON, set the desired value of "auxiliary time" parameter.
- 17) Set "SET TEMPERATURE", setting the motor thermal sensor type used.
- 18) Set "MAIN CONT VOLTAGE", setting the main contactor coil voltage.

8.8 Sequence for Ac Inverter Pump setting

When the "Key Switch" is closed, if no alarms or errors are present, the Console Display will be showing the Standard Zapi Opening Display.

If the controller is not configured to your requirements, follow the sequence detailed here following. Remember to re-cycle the Key Switch if you make any changes to the controller's configuration.

- 1) Select the Options required. See Chapter 8.4.2.
- 2) Select and set the Battery Voltage. See Chapter 8.4.2.
- 3) Confirm correct installation of all wires. Use the Console's TESTER function to assist.
- 4) Perform the lift signal acquisition procedure using the Console "PROGRAM VACC". Procedure is detailed on Chapter 9.3.
- 5) Set the "MAXIMUM CURRENT" Current, using the table on Chapter 8.5.2.
- 6) Set the Acceleration and Deceleration Delay requirements for the pump.
- 7) Set the "MIN SPEED LIFT" level starting from 12.0 Hz. The pump should just turn when the request microswitch is closed. Increase the level accordingly.
- 8) Set the Speed Reductions as required. Make adjustments to "CUTBACK SPEED". Check the performance with the full request. Check the performance with and without load.

- 9) Set "MAX SPEED LIFT" (max speed of pump motor).
- 10) Set "HYD SPEED FINE" to adjust the hydraulic steering speed (pump motor speed when HYDRO function is requested).
- 11) Set "AUXILIARY TIME" (time delay before pump stops when an hydraulic steering function request is switched off).
- 12) Set "SET TEMPERATURE", setting the motor thermal sensor type used.
- 13) Set "AUX OUTPUT VOLTAGE" (if used), setting the auxiliary output voltage.

8.9 Tester: description of the "COMBIAC2" and "COMBIAC2 Power" function

The most important input or output signals can be measured in real time using the TESTER function of the console. The Console acts as a multimeter able to read voltage, current and temperature. In the following chapter a list of relative measurements for different configurations.

8.9.1 Traction

- 1) **MOTOR VOLTAGE**
This is the voltage supplied to the motor by the inverter; it is expressed as a percentage of the full voltage (which depends of the battery voltage).
- 2) **FREQUENCY**
This is the frequency of the voltage and current supplied to the motor.
- 3) **ENCODER**
This is the speed of the motor, expressed in the same unit of the frequency; this information comes from the speed sensor.
- 4) **SLIP VALUE**
This is the difference of speed between the rotating field and the shaft of the motor, expressed in the same unit of the frequency.
- 5) **CURRENT RMS**
Root Mean Square value of the motor current.
- 6) **TEMPERATURE**
The temperature measured on the aluminum heat sink holding the MOSFET devices.
- 7) **MOTOR TEMPERAT.**
This is the temperature of the traction motor; if the option is programmed "None" (see chapter 8.4.1) it shows 0°.
- 8) **ACCELERATOR**
The voltage of the accelerator potentiometer's wiper (CPOT). The voltage level is shown on the Left Hand Side of the Console Display and the value in percentage is shown on the Right Hand Side.
- 9) **FORWARD SWITCH**
The level of the Forward direction digital input FW.
 - ON / +VB = input active, switch closed.
 - OFF / GND = input non active, switch open.
- 10) **BACKWARD SWITCH**
The level of the Reverse direction digital input BW.
 - ON / +VB = input active, switch closed.
 - OFF / GND = input non active, switch open.
- 11) **ENABLE SWITCH**
The level of the Enable digital input:
 - ON / +VB = input active, switch closed.
 - OFF / GND = input non active, switch open.
- 12) **SEAT SWITCH**

The level of the Seat Microswitch digital input.

- ON / +VB = input active, switch closed.
- OFF / GND = input non active, switch open.

13) CUTBACK SWITCH

The level of the Speed Reduction Microswitch.

- ON / GND = input active, switch opened.
- OFF / +VB = input non active, switch closed.

14) BRAKE SWITCH

The level of the Pedal Brake Microswitch.

- ON / +VB = input active, switch closed.
- OFF / GND = input non active, switch open.

15) BRAKE PEDAL POT

The percentage of the pressure on the brake pedal (100% if the pedal is totally pressed, 0% if the pedal is released).

16) VOLTAGE BOOSTER

This is the booster of the voltage supplied to the motor in load condition; it is expressed in a percentage of the full voltage.

17) BATTERY VOLTAGE

Level of battery voltage measured at the input of the key switch.

18) BATTERY CHARGE

The percentage Charge level of the battery.

8.9.2 Pump

1) MOTOR VOLTAGE

This is the voltage supplied to the motor by the inverter; it is expressed as a percentage of the full voltage (which depends of the battery voltage).

2) FREQUENCY

This is the frequency of the voltage and current supplied to the motor.

3) ENCODER

This is the speed of the motor, expressed in the same unit of the frequency; this information comes from the speed sensor.

4) SLIP VALUE

This is the difference of speed between the rotating field and the shaft of the motor, expressed in the same unit of the frequency.

5) CURRENT RMS

Root Mean Square value of the motor current.

6) TEMPERATURE

The temperature measured on the aluminum heat sink holding the MOSFET devices.

7) MOTOR TEMPERAT.

This is the temperature of the pump motor; if the option is programmed "None" (see chapter 8.4.2) it shows 0°.

8) VOLTAGE BOOSTER

This is the booster of the voltage supplied to the motor in load condition; it is expressed in a percentage of the full voltage.

9) BATTERY VOLTAGE

Level of battery voltage measured at the input of the key switch.

10) SEAT SWITCH

The level of the Seat Microswitch digital input.

- ON / +VB = input active, switch closed.
- OFF / GND = input non active, switch opened.

11) FORWARD SWITCH

The level of the Forward direction digital input FW.

- ON / +VB = input active, switch closed.
- OFF / GND = input non active, switch opened.

12) BACKWARD SWITCH

The level of the Reverse direction digital input BW.

- ON / +VB = input active, switch closed.
- OFF / GND = input non active, switch opened.

13) ENABLE SWITCH

The level of the Enable digital input:

- ON / +VB = input active, switch closed.
- OFF / GND = input non active, switch open.

14) LIFTING SWITCH

Status of the lifting switch.

- ON / +VB = active entry of closed switch.
- OFF / GND = non active entry of open switch.

15) HYDRO SPEED REQ.

Status of the hydro speed request of the pump

- ON / +VB = input active, switch closed.
- OFF / GND = input non active, switch open.

16) LIFTING CONTROL

From 0.0 to 5.0 V. The voltage on the wiper of the lift potentiometer (CPOTLIFT on CNC#17) is halved inside the controller and then recorded on this reading. That means the actual wiper voltage is in the range 0 to 10 V meanwhile the corresponding potentiometer reading is in the range 0.0 to 5.0 Vdc.

Flow Chart showing how to use the TESTER function of the Digital Console.

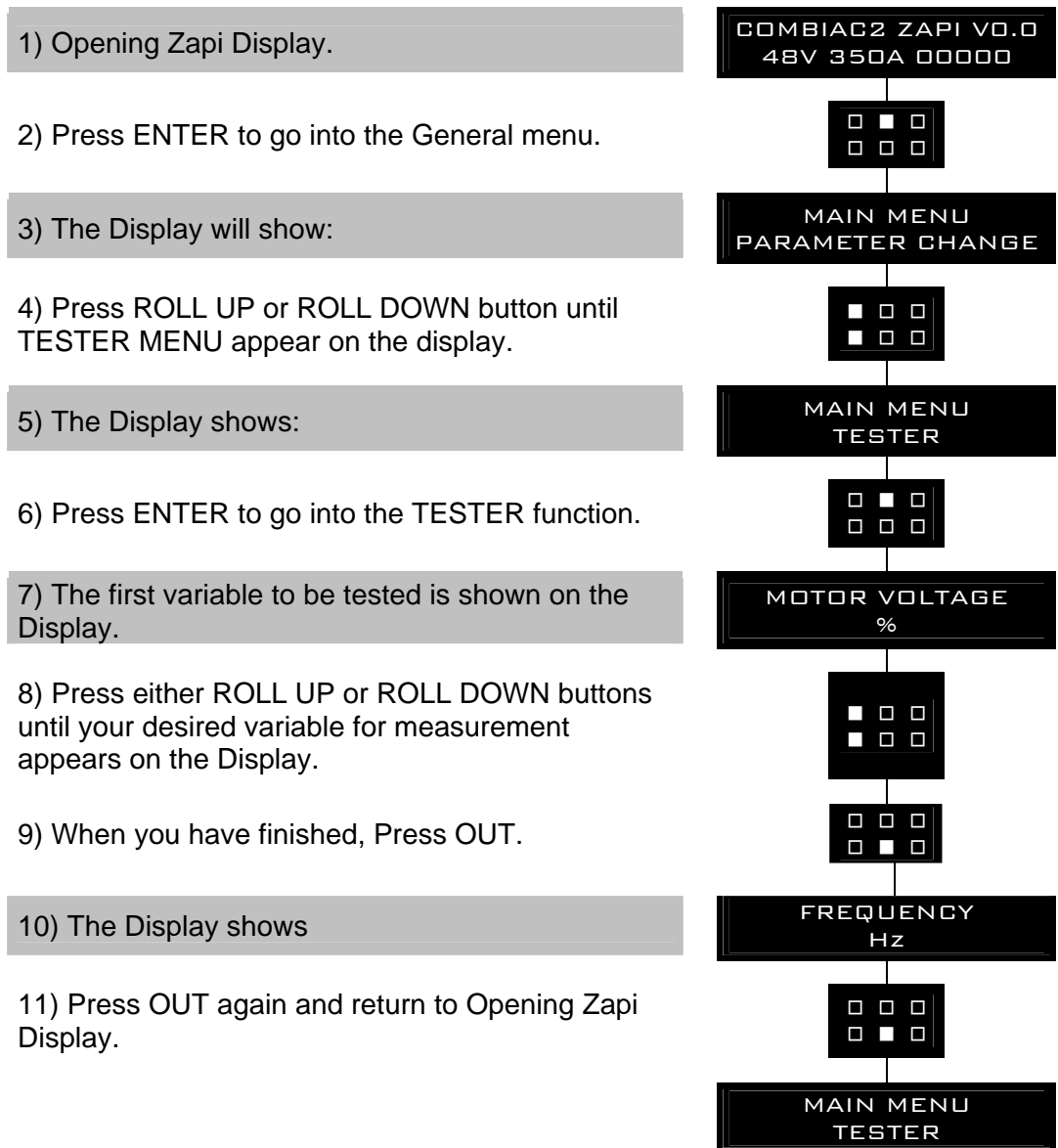

Remember it is not possible to make any changes using TESTER. All you can do is measure as if you were using a pre-connected multimeter.

9 OTHER FUNCTIONS

9.1 Save and Restore function

SAVE function allows to transfer controller parameters to the Pc console memory. With this function, a copy of the controller set of parameters can be retained in a Pc and downloaded to another controller (see RESTORE). RESTORE function allows to download controller parameters from the Pc console memory to the controller Eeprom. Thus a copy of the parameters stored in a Pc can be downloaded in a controller avoiding the parameter setting operation.

For more details, please refer to Pc console manual.

9.2 Description of Alarms menu

The microprocessor in the controller records the last five Alarms that have occurred. Items remembered relative to each Alarm are : the code of the alarm, the number of times the particular Alarm occurred, the Hour Meter count, and the chopper temperature.

This function permits a deeper diagnosis of problems as the recent history can now be accessed.

Flow Chart showing how to use the ALARMS function via the Digital Console.

1) Opening Zapi Display.

```
COMBIAC2 ZAPI V0.0
48V 350A 00000
```

2) Press ENTER to go into the General menu.

```
□ ■ □
□ □ □
```

3) The Display will show:

```
MAIN MENU
PARAMETER CHANGE
```

4) Press ROLL UP or ROLL DOWN button until PARAMETER CHANGE appears on the display.

```
■ □ □
■ □ □
```

5) The Display will show:

```
MAIN MENU
ALARMS
```

6) Press ENTER to go into the ALARMS function.

```
□ ■ □
□ □ □
```

7) The Display will show the most recent Alarm.

```
CODE
00005 #02 20°C
```

8) Each press of the ROLL UP button brings up following Alarms. Pressing ROLL DOWN returns to the most recent.

```
■ □ □
■ □ □
```

9) If an Alarm has not occurred, the Display will show: ALARM NULL.

```
CODE
00007 #03 18°C
```

10) When you have finished looking at the Alarms, press OUT to exit the ALARMS menu.

11) The Display will ask "CLEAR LOGBOOK?".

12) Press ENTER for yes, or OUT for NO.

13) Press OUT to return to the Opening Zapi Display.

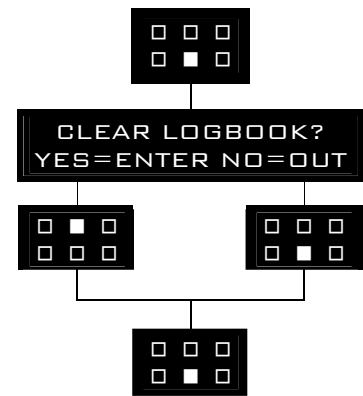

9.3 Description of Console Program Vacc function

This function looks for and remembers the minimum and maximum potentiometer wiper voltage over the full mechanical range of the pedal. It enables compensation for non symmetry of the mechanical system between directions. The operation is performed by operating the pedal after entering the PROGRAM VACC function.

Flow Chart showing how to use the PROGRAM VACC function of the Digital Console:

1) Opening Zapi Display.

2) Press ENTER to go into the General Menu.

3) The Display will show:

4) Press ROLL UP or ROLL DOWN button until PROGRAM VACC appears on the display.

5) The Display will show:

6) Press ENTER to go into the PROGRAM VACC routine.

7) The Display will show the minimum and maximum values of potentiometer wiper output. Both directions can be shown.

8) Press ENTER to clear these values. Display will show 0.0.

9) Select Forward Direction, close any interlock switches that may be in the system.

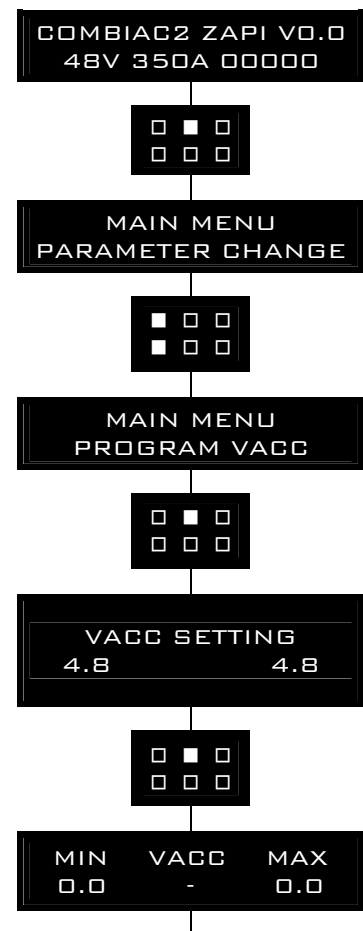

10) Slowly depress the accelerator pedal (or tiller butterfly) to its maximum value. The new minimum and maximum voltages will be displayed on the Console plus an arrow indicating the direction.

11) Select the Reverse Direction and repeat Item 10.

12) When finished, press OUT.

13) The Display will ask: "ARE YOU SURE?".

14) Press ENTER for yes, or OUT for NO.

15) When finished, the Console shows:

16) Press OUT again to return to the Opening Zapi Menu.

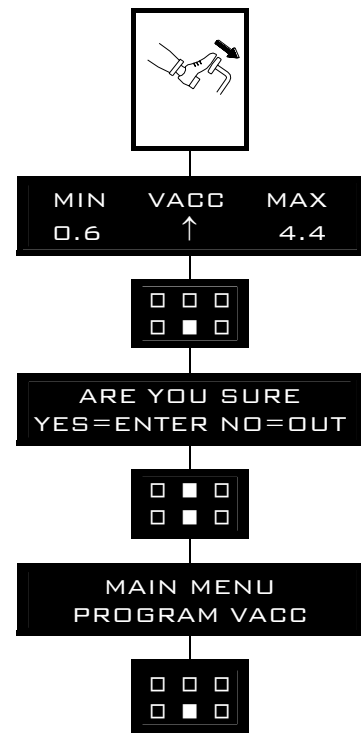

10 "COMBIAC2" INVERTER DIAGNOSTIC

10.1 Fault codes

Code	ALARM STRING	Traction	Pump	CONTROLLER STATUS			DESCRIPTION	Condition that has to occur to come out from alarm status
				Init	Stby	Motor running		
8	WATCHDOG	X	X	X	X	X	<u>Alarm:</u> the Watchdog circuit has been triggered	-If the alarm is present in Init status,remove the alarm condition -If the alarm has occurred in stby or running mode, it is necessary to remove alarm condition and to activate a traction request
17	LOGIC FAILURE #3	X	X		X		<u>Alarm:</u> failure in over-load protection hw circuit	To remove alarm condition + activation of traction request
18	LOGIC FAILURE #2	X	X	X			<u>Alarm:</u> failure in U,V,W voltage feedback circuit	To remove alarm condition + activation of traction request
19	LOGIC FAILURE #1	X	X	X	X	X	<u>Alarm:</u> an overvoltage or undervolt. condition has been detected	To recycle the key switch
30	VMN LOW	X	X	X	X	X	<u>Alarm:</u> wrong voltage on motor power outputs; failure in the power section or in the mosfet driver circuit or in the motor	-If the alarm is present in Init status,remove the alarm condition -If the alarm has occurred in stby or running mode, it is necessary to remove alarm condition and to activate a traction request

Code	ALARM STRING	Traction	Pump	CONTROLLER STATUS			DESCRIPTION	Condition that has to occur to come out from alarm status
				Init	Stby	Motor running		
31	VMN HIGH	X	X	X	X		Alarm: wrong voltage on motor power outputs; failure in the power section or in the mosfet driver circuit or in the motor	-If the alarm is present in Init status,remove the alarm condition -If the alarm has occurred in stby or running mode, it is necessary to remove alarm condition and to activate a traction request
53	STBY I HIGH	X	X	X	X		Alarm: wrong voltage in the current sensor feedback circuit	-If the alarm is present in Init status,remove the alarm condition -If the alarm has occurred in stby or running mode, it is necessary to remove alarm condition and to activate a traction request
60	CAP CHARGE	X	X	X			Alarm: power capacitor voltage does not increase when the key is turned ON; failure in the power section, or in the Logic PCB, or in the driver PCB, or in the motor	To remove alarm condition
74	DRIVER SHORTED	X		X	X	X	Alarm: line contactor coil driver is shorted	-If the alarm is present in Init status, remove the alarm cause -If the alarm has occurred in stby or running mode, it is necessary to remove alarm cause and to activate traction request
75	CONTACTOR DRIVER	X			X	X	Alarm: line contactor coil driver is open (not able to drive the coil to the correct voltage)	To remove alarm cause and to activate traction request

<u>Code</u>	<u>ALARM STRING</u>	<u>Traction</u>	<u>Pump</u>	<u>CONTROLLER STATUS</u>			<u>DESCRIPTION</u>	<u>Condition that has to occur to come out from alarm status</u>
				<u>Init</u>	<u>Stby</u>	<u>Motor running</u>		
76	COIL SHORTED	X		X	X	X	<u>Alarm:</u> -Init: the LC and EB coil driver protection circuit is damaged - Stby or running: short on LC coil or EB coil	-If the alarm is present in Init status, remove the alarm cause -If the alarm has occurred in stby or running mode, it is necessary to remove alarm cause and to activate traction request
37	CONTACTOR CLOSED	X		X			<u>Alarm:</u> line contactor power contact is stuck	To remove alarm cause within a timeout; if the timeout is elapsed, it is necessary to re-cycle the key
38	CONTACTOR OPEN	X		X			<u>Alarm:</u> line contactor power contact does not pull-in	To remove alarm cause within a timeout; if the timeout is elapsed, it is necessary to re-cycle the key
82	ENCODER ERROR	X	X			X	<u>Alarm:</u> motor speed sensor (encoder) does not work properly	To recycle the key
86	PEDAL WIRE KO		X	X	X	X	<u>Alarm:</u> fault in accelerator negative (NPOT) input circuit	To remove alarm cause and activate a traction request
245	WRONG SET BATTERY	X		X			<u>Alarm:</u> the battery voltage does not correspond to SET BATTERY programmation	To remove alarm cause
246	PUMP KO	X		X	X	X	<u>Alarm:</u> Traction μ C detects a Pump μ C malfunctioning	To recycle the key

Code	ALARM STRING	Traction	Pump	CONTROLLER STATUS			DESCRIPTION	Condition that has to occur to come out from alarm status
				Init	Stby	Motor running		
246	MASTER KO		X	X	X	X	<u>Alarm</u> : Pump μ C detects a Traction μ C malfunctioning or a mismatch between inputs status and Traction commands (via Canbus)	To recycle the key
250	INPUT MISMATCH		X	X	X	X	<u>Alarm</u> : Pump μ C has detected a mismatch between inputs status and the input status transmitted via Canbus by Traction μ C	To recycle the key
253	AUX OUTPUT KO	X		X	X	X	<u>Alarm</u> : EB coil driver shorted or open	-If the alarm is present in Init status, remove the alarm cause -If the alarm has occurred in stby or running mode, it is necessary to remove alarm cause and to activate traction request
13	EEPROM KO	X	X	X	X	X	<u>Warning</u> : Eeprom fault, controller will use default parameters	To remove Warning cause
61	HIGH TEMPERATURE	X	X	X	X	X	<u>Warning</u> : Traction or Pump or both temperature higher than 75°C	To remove Warning cause
65	MOTOR TEMPERATURE	X	X	X	X	X	<u>Warning</u> : Traction or Pump or both motors temperature high	To remove Warning cause
66	BATTERY LOW	X		X	X	X	<u>Warning</u> : battery charge level below 20%	To remove Warning cause

<u>Code</u>	<u>ALARM STRING</u>	<u>Traction</u>	<u>Pump</u>	<u>CONTROLLER STATUS</u>			<u>DESCRIPTION</u>	<u>Condition that has to occur to come out from alarm status</u>
				<u>Init</u>	<u>Stby</u>	<u>Motor running</u>		
78	VACC NOT OK	X		X	X		<u>Warning:</u> accelerator signal (CPOT) voltage higher than VACC MIN +1V while the traction enable switch is open	To remove Warning cause
79	INCORRECT START	X		X	X	X	<u>Warning:</u> wrong traction request sequence	To remove Warning cause
80	FORWARD + BACKWARD	X		X	X	X	<u>Warning:</u> forward and reverse inputs are both active	To remove Warning cause
249	THERMIC SENSOR KO	X	X	X	X	X	<u>Warning:</u> Traction or Pump temperature sensor is out of range	To remove Warning cause
251	WAITING FOR NODE#5	X		X	X	X	<u>Warning:</u> Traction μ C signals that Pump μ C is in alarm status	To remove Warning cause
251	WAITING FOR NODE#3		X	X	X	X	<u>Warning:</u> Pump μ C signals that Traction μ C is in alarm status	To remove Warning cause
247	NO CAN MESSAGE #5	X		X	X	X	<u>Alarm:</u> Traction has lost Can communication with the Pump	To remove Warning cause
247	NO CAN MESSAGE #3		X	X	X	X	<u>Alarm:</u> Pump has lost Can communication with the Traction	To remove Warning cause
242	PUMP WARNING	X		X	X	X	<u>Warning:</u> Traction controller signals that Pump μ C has detected a fault in the pump chopper	To remove warning cause

Code	ALARM STRING	Traction	Pump	CONTROLLER STATUS			DESCRIPTION	Condition that has to occur to come out from alarm status
				Init	Stby	Motor running		
243	PUMP INC. START		X	X	X		Warning: pump incorrect start sequence	To remove warning cause
244	PUMP VACC NOT OK		X	X	X		Warning: pump accelerator voltage is 1V greater than the minimum value programmed	To remove warning cause

10.2 Analysis of alarms displayed on console

1) WATCH DOG

It is a self-diagnosis test within the logic between Traction and Pump μ controllers. This alarm could also be caused by a canbus malfunctioning, which blinds Traction-Pump communication. So, before replacing the controller, check the canbus.

2) LOGIC FAILURE #3

Fault in the hardware section of the logic board which manages the hardware current protection. Replace the logic board.

3) LOGIC FAILURE #2

Fault in the hardware section of the logic board which manages the phase's voltage feedback. Replace the logic board.

4) LOGIC FAILURE #1

This alarm signals that the undervoltage / overvoltage protection interrupt has been triggered. Two possible reasons:

- B) A real undervoltage / overvoltage situation happened.
- C) Fault in the hardware section of the logic board which manages the overvoltage protection. Replace the logic card.

5) VMN LOW, VMN HIGH

The test is carried out during initial diagnosis and in standby.

Possible causes:

- A) problem with the motor connections or the motor power circuit; check if the 3 phases are correctly connected; check if there's a dispersion of the motor to truck frame.
- B) fault in the inverter power section, replace the controller.

6) STBY I HIGH

The μ Cs verify if the feedback of current sensors device output is within the zero current window. Possible causes of the alarm:

- C) current sensor failure;
- D) failure in the logic card: first replace the logic card; if the defect persists, replace the power unit.

7) CAPACITOR CHARGE

Follows the charging capacitor system:

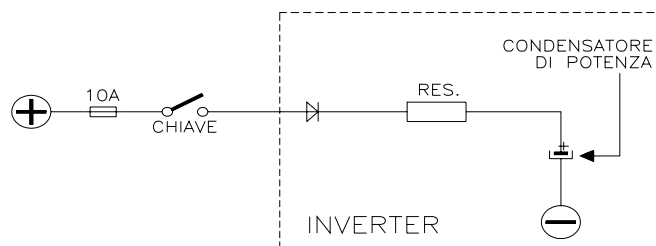

When the key is switched ON, the inverter tries to charge the capacitor through a power resistance, and check if the capacitor are charged within a timeout. If they do not charge, an alarm is signalled; the main contactor is not closed.

Possible reasons:

- A) the charging resistance is opened.
- B) The charging circuit has a failure.
- C) There is a problem in the power section.

8) MAIN CONTACTOR ALARMS

1. COIL SHORTED:

When the key is switched ON the μ Controller checks the LC coil driver shortcircuit protection hardware. If it does not react in a correct way to the μ C stimulus, the alarm is signalled. Replace the logic board. When the fault occurs while the LC is closed, the alarm signals a shortcircuit across LC coil.

Check if there are external shortcircuit and if the ohmic value of the MC coil is correct; otherwise replace the logic.

2. DRIVER SHORTED:

When the key is switched ON, the μ C checks that the LC coil driver is not shorted; if it is, this alarm is signalled. Preliminary, check if there is an external short or low impedance pull-down between NLC (C26) and -BATT. If no external causes can be found out, replace the controller.

3. CONTACTOR DRIVER:

When the initial diagnosis is finished, the traction logic closes the LC and checks the voltage on the Drain of the driver. If this is not low, the driver is not able to close an alarm is signalled. Replace the logic.

4. CONTACTOR OPEN:

The main contactor coil has been driven by the logic board, but the contactor does not close. Two possible reasons:

- A) the wires to the coil are interrupted or not well connected.
- B) the contact of the contactor is not properly working (does not pull-in).

5. CONTACTOR CLOSED:

Before driving the LC coil, the controller checks if the LC contact is stuck. The controller drives the bridge for a while, trying to discharge the capacitor bank. If they don't discharge, the fault condition is entered. It is suggested to check the contactor contact, if it is mechanically stuck.

9) ENCODER ERROR

This alarm is signalled in following condition: the frequency supplied to the motor is higher than 20 Hz, and the signal feedback from the encoder has a jump higher than 20 Hz in few tens millisecond. This condition clearly shows a malfunctioning of the encoder signal. It is suggested to preliminary check the encoder wiring; if no fault is found in the wiring it is necessary to replace the encoder.

10) PEDAL WIRE KO

This alarm is signalled if a fault is detected in the accelerator unit wiring (NPOT or PPOT cable is interrupted).

11) WRONG SET BATTERY

When the key is turned ON, the controller check the battery voltage and compares it with the "SET BATTERY" parameter setting. If the actual value is 20% higher or lower than nominal value, the fault condition is entered.

Replace the battery with a correct battery.

12) PUMP KO

Pump and traction μ Cs perform a cross-check in order to verify their functionality. If the Traction detects Pump μ C malfunctioning, it brings the controller in a safe status opening the power bridge and the Line Contactor.

13) MASTER KO

Pump and Traction μ Cs perform a cross-check in order to verify their functionality. There are two conditions under which pump enters this fault condition:

- A) the Pump μ C receives incoherent can message from the Traction μ C.
- B) the Pump μ C compares the inputs status and the related Traction operations, and find they are not coherent.

In both cases, the Pump brings the controller to a safe status opening the power bridge and the Line contactor.

14) INPUT MISMATCH

Safety related inputs (Fw direction, Rev direction, accelerator ENABLE, SEAT switch) are input to both microcontrollers by independent hw circuit. The two μ Cs read these inputs and compare by exchanging related status on the canbus. If the Pump μ C finds a mismatch between its inputs and Traction inputs, it brings the controller to a safe status opening the power bridge and the Line contactor.

15) AUX OUTPUT KO

The μ P checks the driver of the electromechanical brake coil. If the status of the driver output does not correspond to the signal coming from the μ P, the alarm is signalled. It is suggested to preliminary check if there is an external short or low impedance pull-down between NAUX (C31) and -BATT. If no external cause can be found, replace the logic card.

16) EEPROM KO

Fault in the area of memory in which the adjustment parameters are stored; this alarm does not inhibits truck operation, but the controller will use default parameters. If the defect persists when the key is switched OFF and ON again, replace the logic. If the alarm disappears, remember that the parameters stored previously have been cancelled and replaced by the default values.

17) HIGH TEMPERATURE

Traction or Pump or both temperatures are greater than 75°C. The maximum current is reduced proportionally to the temperature increase. At 100°C the max current of both inverter is reduced to zero.

If the alarm is signalled when the controller is cold:

- A) thermal sensor failure.
- B) failure in the logic card.

18) MOTOR TEMPERATURE

This warning is signalled if traction or pump or both motors temperature switches open (digital sensor) or if the analog signals overtakes the cut off level. If it happens when the motor is cold, check the wiring. If all is ok, replace the logic board.

19) BATTERY LOW

If the "battery check" option is ON, a battery discharge algorithm is carried

out. When the charge level is 20% , this alarm is signalled and the current is reduced to the half of the programmed level.

20) VACC NOT OK

The test is made in standby. This alarm indicates that the accelerator voltage is 1 V greater than the minimum value programmed by the PROGRAM VACC function.

Possible causes:

- A) the potentiometer is not correctly calibrated.
- B) the potentiometer is defective.

21) INCORRECT START

This alarm signals an incorrect starting sequence. Possible causes:

- A) Fw or Rev or Enable microswitch failure;
- B) error in sequence made by the operator;
- C) incorrect wiring;

if the default persists after checking the harness, replace the logic.

22) FORW + BACK

The test is carried out continuously. An alarm is signalled when a double running request is made simultaneously. Possible causes:

- A) defective wiring;
- B) running microswitch failure;
- C) incorrect operation;

if the defect persists, replace the logic.

23) THERMIC SENSOR KO

The range of inverter temperature sensor is always checked and a warning is signalled if it is out of range.

When this alarm is signalled, the maximum current of the controller is reduced to halt.

24) WAITING FOR NODE #5

The Pump has detected a failure, the Traction cannot close the main contactor because of the alarm status of the Pump (which the Traction knows by the CAN-BUS line). The failure must be looked for in the Pump controller, use the remote console to get connection to the Pump μ C.

25) WAITING FOR NODE #3

The Traction μ C has detected a fault condition, the Pump is aware of this thanks to canbus communication; it cannot drive the motor until the Traction has resolved its problem. The fault has to be looked for in the Traction.

26) NO CAN MESSAGE #5

Traction (node #3) signals that it has lost can communication with the Pump (node #5). This fault could be determined by a problem in the truck canbus line or by an internal problem in the controller logic card.

It is suggested to preliminary check canbus connection.

27) NO CAN MESSAGE #3

Pump (node #5) signals that it has lost can communication with the Traction (node #3). This fault could be determined by a problem in the truck canbus line or by an internal problem in the controller logic card.

It is suggested to preliminary check canbus connection.

28) PUMP WARNING

This is a warning in the Traction controller, which inform that the Pump is in a pump chopper related fault condition.

29) PUMP INC. START

This is a warning in the Pump controller, which inform that an incorrect start sequence happened on the pump.

30) PUMP VACC NOT OK

This is a warning in the Pump controller, which inform that lift potentiometer voltage is 1V greater than the minimum value programmed.

11 RECOMMENDED SPARE PARTS FOR INVERTER

Part Number	Description
C16507	Protected 500 A strip Fuse
C16505	Protected 355 A strip Fuse
C16520	6.3 A 20 mm Control Circuit Fuse
C29523	SW 180 80 V Single Pole Contactor
C29522	SW 180 48 V Single Pole Contactor
C29508	SW 180 24 V Single Pole Contactor

12 PERIODIC MAINTENANCE TO BE REPEATED AT TIMES INDICATED

Check the wear and condition of the Contactors' moving and fixed contacts. Electrical Contacts should be checked every **3 months**.

Check the Foot pedal or Tiller microswitch. Using a suitable test meter, confirm that there is no electrical resistance between the contacts by measuring the volt drop between the terminals. Switches should operate with a firm click sound. Microswitches should be checked every **3 months**.

Check the Battery cables, cables to the chopper, and cables to the motor. Ensure the insulation is sound and the connections are tight. Cables should be checked every **3 months**.

Check the mechanical operation of the pedal or tiller. Are the return springs ok. Do the potentiometers wind up to their full or programmed level. Check every **3 months**.

Check the mechanical operation of the Contactor(s). Moving contacts should be free to move without restriction. Check every **3 months**.

Checks should be carried out by qualified personnel and any replacement parts used should be original. Beware of NON ORIGINAL PARTS. The installation of this electronic controller should be made according to the diagrams included in this Manual. Any variations or special requirements should be made after consulting a Zapi Agent. The supplier is not responsible for any problem that arises from wiring methods that differ from information included in this Manual.

During periodic checks, if a technician finds any situation that could cause damage or compromise safety, the matter should be brought to the attention of a Zapi Agent immediately. The Agent will then take the decision regarding operational safety of the machine.

Remember that Battery Powered Machines feel no pain.

NEVER USE A VEHICLE WITH A FAULTY ELECTRONIC CONTROLLER.