

INDEX

	Page
Legend	2
1 Introduction to the ZAPIMOS family	3
2 Characteristics	4
2.1 Specifications	4
2.2 Control units	5
2.2a Microswitches	5
2.2b Potentiometer	5
2.3 Speed	7
2.4 Safety devices	7
2.5 Performance	8
2.6 Thermic considerations	9
2.7 General advices 	9
2.8 Susceptibility and electromagnetic emission	9
3 Installation	10
3.1 Choice connecting cable	10
3.2 Contactors	10
3.3 Fuses	10
3.4 Mechanical drawing	11
3.5 Connector description	12
3.6 Power connector description	14
3.7 Description of the connections	14
3.8 Diodes	15
4 Settings	16
4.1 Description of variable parameters	17
4.2 Parameter change via economic console	18
4.3 Description of digital console functions	19
4.4 Sequence of settings H1DN	20
5 H1DN diagnosis	21
5.1 Decoding of the alarms on display	22
6 Schematic diagrams	25
6.1 Description of H1DN 3 cables 2Q layout	25
Connection diagram of H1DN 2Q (tiller)	26
Connection diagram of H1DN 2Q (pedal)	27
6.2 H1DN AUTOSTOP	28
6.3 Description of H1DN 4 and 3 cables 1Q	28
Connection diagram of H1DN 4 cables with changeover contactors 1Q (tiller)	29
Connection diagram of H1DN 4 cables with changeover contactors 1Q (pedal)	30
Connection diagram of H1DN 3 cables 1Q (tiller)	31
Connection diagram of H1DN 3 cables 1Q (pedal)	32
Spare parts	33
Periodic Maintenance	34



= The informations included into the marked paragraphs by this symbol are essential for the safety.

Publication n°.: **550114B**

Edition: **July 1994**

LEGEND

1Q	=	1 Quadrant
2Q	=	2 Quadrants
AV	=	Forward
BTA	=	Forward contactor coil
BTG	=	General contactor coil
BTI	=	Backward contactor coil
BTP	=	Pump contactor coil
CH	=	Key
CL	=	Horn
EF	=	Electrobrake coil
EV	=	Electrovalve coil
IN	=	Reverse
IND	=	Weakening
M.UM	=	Belly switch
MA	=	Forward microswitch
MCL	=	Horn switch
MD	=	Down microswitch
MEF	=	Electric brake switch
MI	=	Reverse microswitch
MSOL	=	Lifting switch
MT	=	Tiller switch
MU	=	Up microswitch
NT	=	Contactor minus
POT	=	Potentiometer
RV1	=	Speed reduction 1
TA	=	Forward physical contact
TG	=	General physical contact
TI	=	Backward physical contact
VMN	=	Motor minus voltage

1 INTRODUCTION TO THE ZAPIMOS FAMILY

The Zapimos chopper family is the solution offered by ZAPI to meet the users' requirements in the 90's.

To ensure that the product remain on the market for a sufficiently long period of time without running the risk of becoming technically obsolete, ZAPI has designed the Zapimos family which features the following specifications:

- Advanced technology
- Top safety
- Very high flexibility
- Possibility of updating based on future technological innovations
- Very high level of protection.

This includes :

- High frequency Mos technology
- Real-time control of inner and outer components which may affect machine behaviour with self-diagnosis of the control circuits.
- Recorded program machine (SPC) where the physical component (hardware) is kept completely separated from the functions to be implemented.

The program is parametric with possibility of intervention on the part of the end user.

- Any in-house technological updating is made clear to the user.

The communication protocol will evolve over the next few years to offer increasing possibilities of interaction.

For this purpose the Zapimos family features a dialog mode with standard external system to be easily interfaced with commercially available machines.

ZAPI also offers a wide range of Programming Consoles with different types of performance and different prices.

- Logic and power units are fitted in a semi - enclosed case (IP54) to ensure protection against splashes (water, acid, etc.), dust, chips and smallware.

Access to the logic unit remains very easy allowing for quick replacement or inspection.

H1DN is the smallest chopper of this family. It is suitable for operation on voltage 24V with motors in the range 500W to 2KW. An interesting option is a completely static version with 3-cable motors.

2 CHARACTERISTICS

2.1 SPECIFICATIONS

Chopper H1DN is suitable for controlling 3 and 4 terminal series wound motors.

- Frequency** : 18 KHz
Voltage : 24V (16 - 30)
Max Current : 2 Quadrants - 150A for 4 min.
 1 Quadrant - 300A for 2 min.
Temperature : -30° : +40°C

CONFIGURATION	CURRENT	CONTACTORS	DIODI FRENO	DROP VOLTAGE (1/3 IMAX)
3 CABLES 2Q	150A	GENERAL	NO	200mV
3 CABLES 1Q	300A	FW - REV	SI	200mV
4 CABLES 1Q	300A	FW - REV	SI	200mV

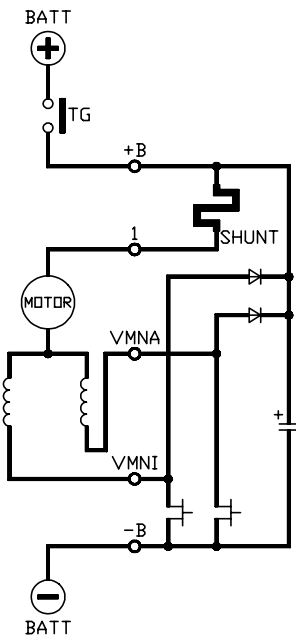

3 CABLES 2Q

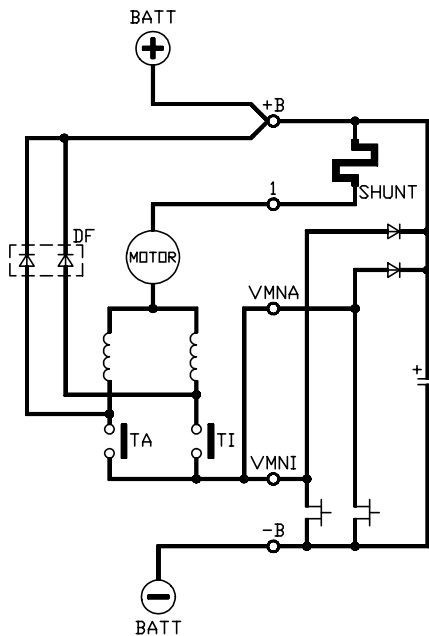

3 CABLES 1Q

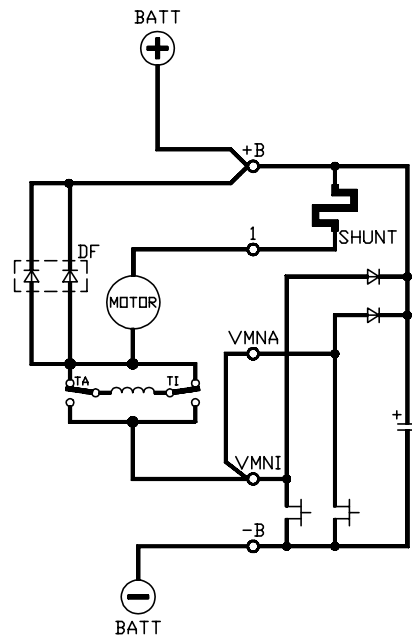

4 CABLES 1Q

2.2 CONTROL UNITS

2.2a Microswitches

Microswitches send a voltage signal when a direction request or a desired function is activated. The tiller microswitch or the dead man microswitch conduct the current to exit the contactors and the electrobrake. They should be able to handle currents up to 5 amps. For safety reasons it is mandatory to use this microswitch according to the reported diagrams. To stop the chopper there are 4 possible levels:

1. Chopper opens up the contactors automatically through its safety features in a time shorter than 100 msecs.
2. Open of tiller microswitch or dead man microswitch
3. Key
4. Battery connector

3. and 4. are always of easy access, so that the use of the tiller microswitch gives an effective alternative way to stop the chopper. When the key is turned on this microswitch should be open so that the microprocessor is able to verify its status every time that power is supplied to the chopper.

2.2b Potentiometer

It can be connected in both 2 or 3 wire configurations.

The signal on CPOT (C1) ranges from 0 to 5 volts. In order to have a correct functioning of the 2-wire configuration a 20 Kohm trimmer is present on the logic board. This trimmer is placed between the CPOT (C1) connector and the 13V5 internal power supply. This enables to adjust the signal to different potentiometer values.

In the 2-wire configuration the end of stroke value should range from 300 ohm to 10 Kohm. In the 3-wire configuration the end of stroke value should range from 500 ohm to 10 Kohm. Lower values overload the power supply unit, higher values make it possible linearity errors.

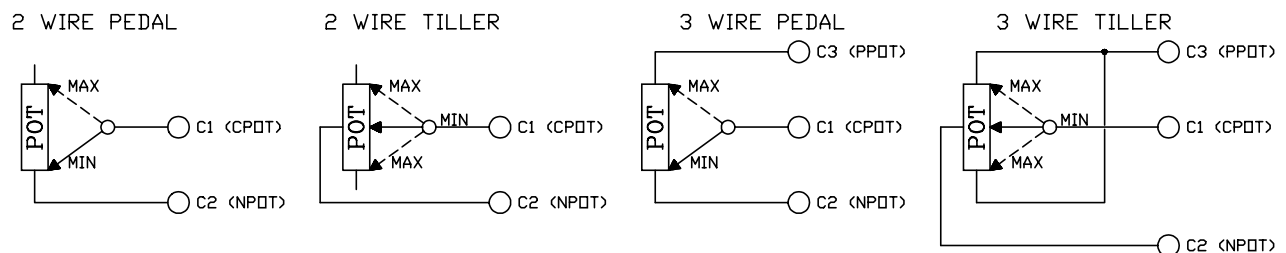

The procedure for automatic potentiometer signal acquisition is carried out from the console. This makes it possible to adjust the minimum and maximum useful signal in the respective directions.

This function is indispensable when it is necessary to compensate for asymmetry in the mechanical workings that control the potentiometer, especially as regards the adjustment of the minimum which in certain cases, if made in the traditional way, requires a calibration that is laborious and costly, but very often gives unsatisfactory results.

The sequence of procedures is described in the programming console manual.

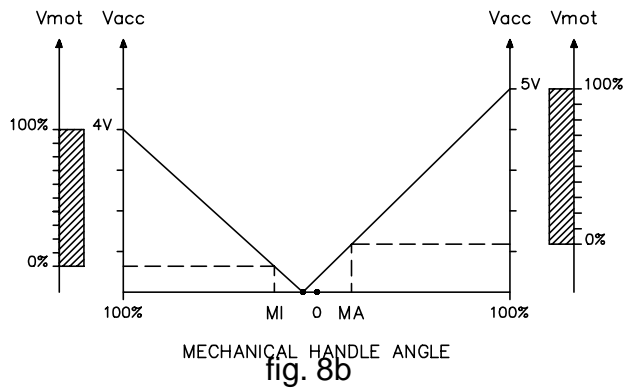
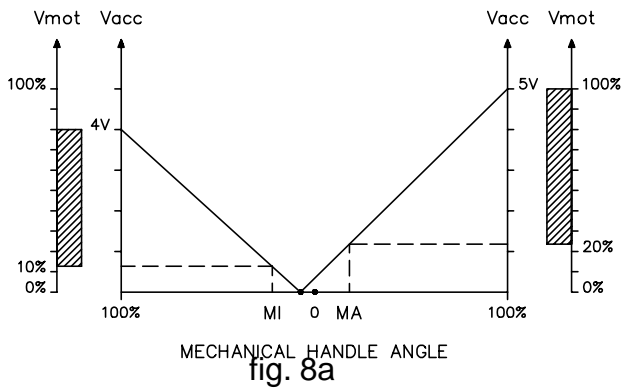

The two graphs show the output voltage from an uncalibrated potentiometer with respect to the mechanical “zero” of the knob of one handle (MI and MA indicate the point at which the speed microswitches close, 0 is the mechanical zero of the handle rotation). The first graph (Fig. 8a) shows the correspondence of the motor voltage without having made the acquisition, while the second graph (Fig. 8b) shows the same correspondence after signal acquisition by the potentiometer.

The acquisition procedure is invalidated by the machine if the difference between the maximum value and the minimum value is less than 2V.

This acquisition procedure makes it possible:

- to use “reversed” potentiometric signals, i.e. those which are carried from a high initial value to a low final value.
- to use a normal potentiometer instead of one with central zero.

For the correct functioning of signal acquisition, it is absolutely necessary that the running microswitches be activated by the same shaft that moves the potentiometer.

Application examples.

- Signal overturn.

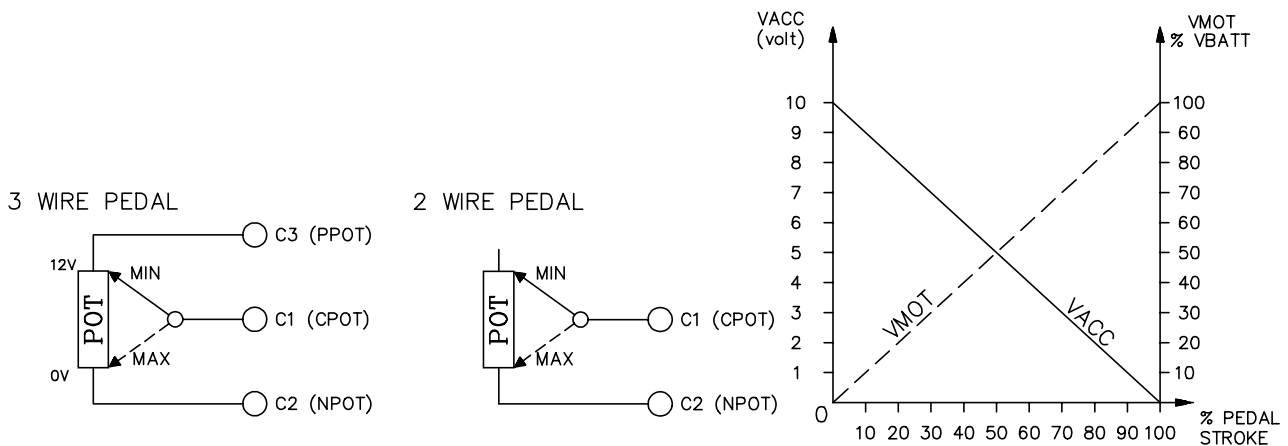

V_{ACC} = accelerator signal voltage to pin C1.
V_{MOT} = percentage of battery voltage on the motor.

2.3 SPEED

Speed may be adjusted:

- Max. speed adjustment from 10 to 100% (via the programming console only).
- Speed reduction device with microswitch go-ahead: RV1 (from 10 to 100%).
- Speed reduction device with microswitch go-ahead: RV2 (from 10 to 100%).

When one of the three reduction devices is in automatic function the chopper adjusts the voltage to keep speed constant.

The feed - back parameter can be changed from the console to obtain the desired characteristic.

2.4 SAFETY DEVICES

- **Battery Inversion**

Already present in the 3-cable version with general contactor; In other versions there should be a main contactor which isolates +Batt (optional).

- **Connection errors**

All inputs are protected against connection errors except for inputs NT1 and NT2 which do not accept direct connections with +Batt or loads greater than 3A.

- **Thermal protection**

If temperature exceeds 75°C the max. current is reduced proportionally to the temperature rise.

Temperature is never allowed to exceed 85°C.

- **Discharged battery**

If the battery is down discharged, max. current is reduced by 50%.

- **External agents**

The chopper is protected against dust and fluid splashes (IP54) as it is semi enclosed.

- **Safety against accidental starting**

A precise sequence of operations is required to start the machine. If such operations are not correctly performed the machine will not start.

They are as follows:

- 1) - Key
 - Handle microswitch
 - Running microswitch
- 2) - Key
 - Seat microswitch (5sec. delayed)
 - Running microswitch

- **Safety against uncontrolled movements**

Contactors will not close if:

- The power unit is not operating.
- The accelerator is not allowed to reach below 1 Volt.
- The logic unit is not operating correctly.
- One of the running microswitches is closed.
- Request for rapid inversion is available independently of the running microswitches.

2.5 PERFORMANCE

- Very good sensitivity at low speed
- Anti-Roll-Back
- Rapid inversion
- Braking with current control
- Electric brake coupling
- Field weakening or bypass control with adjustable output current.
- Diagnosis with failure indication by means of an optional LED.
- Parameter adjustment via the console (see specific paragraph).
- Internal hour meter suitable for being displayed on the console.
- Storing of the last 5 alarms which have occurred with the corresponding hour meter values which can be displayed in the console and chopper temperature.
- Tester function via the console to check main parameters in real time, i.e. inputs, motor voltage and battery voltage.
- The function " DATA MOTOR " optimizes the motor chopper combination, registering the relevant characteristics of the motor that influences the electric braking.

2.6 THERMAL CONSIDERATIONS

- The heat generated by the control unit must be dissipated. For this to be possible, the compartment must be ventilated and the cooling surfaces ample.
- The cooling system is dimensioned on the basis of the performance required of the machine. For situations in which ventilation is poor and heat exchange difficult because of the materials used, it is advisable to use forced air ventilation.
- The power dissipated by the module varies depending on the current and the work cycle.

2.7 GENERAL NOTES AND PRECAUTIONS

- Never combine SCR low frequency choppers with H1DN modules, as the filtre condensers contained in the H1DN module alter SCR chopper functioning, subjecting it to excessive workloads. Thus, if you wish to use two or more control units (e.g. lift + traction), they must all be of the high frequency ZAPIMOS family.
- Do not connect the chopper to a battery with a different nominal voltage than that indicated on the chopper identification plate. A higher battery voltage can cause MOS failure. A lower battery voltage prevents the module from functioning.
- During battery recharge, the H1DN module must be completely disconnected from the battery, as in addition to altering the charge read by the battery charger, the module can be damaged by the overload voltages generated by the charger.
- The H1DN module must only be supplied using a traction use battery; do not use outputs of straighteners or power suppliers. For special applications, consult the nearest ZAPI service centre.
- Start the machine the first time with the wheels raised, to ensure that connection errors do not create safety risks.
- With the key off, the filtre condensers inside the module may remain charged for several minutes. For safe operation, we recommend that you disconnect the battery and short circuit the power positive and negative on the chopper for a few seconds with a resistance of between 10 ohm and 100 ohm.

2.8 SUSCEPTIBILITY AND ELECTROMAGNETIC EMISSION

The electromagnetic susceptibility and emission are remarkably influenced by the modality of installation; a special attention must be put on the length and the paths of the electric connections and the shields.

Therefore ZAPI declines any responsibility regarding the bad-working imputable to above-mentioned cases, especially if the truck's builder doesn't execute the required test from the norm in force. (The emission conducted, the irradiated emission, IEC 801-2 (ESD), IEC 801-3 (irradiated susceptibility), IEC 801-4 (BURST), IEC 801-5 (SURGE), IEC-6 (the immunity conducted)).

3 INSTALLATION

Fit the chopper with its base plate on a flat, unpainted, clean, metal surface.

Apply a thin layer of thermoconductive grease between the two surfaces to ensure optimum heat dissipation.

Even if protection is available against external agents the continuous attack by corrosive agents may cause oxidation of the connector contacts thereby impairing their operation. This factor should be kept well in mind when selecting the location of the chopper within the vehicle.

To fix the chopper, use the suitable holes available in the base plate.

Check that cable terminal and connector cabling has been accurately performed.

It is recommended to fit suppression elements to the horn, solenoid valves, and all contactors not connected to the chopper.

3.1 CHOICE OF CONNECTING CABLES

For auxiliary circuits use cables with 0.5 mm² cross section area.

For power connections to the motor and battery in the 2 Quadrant versions use cables with 16-25 mm² cross section while in the 1 Quadrant versions use cables with 25-35 mm² cross section area.

To increase the chopper performance, the cables connecting to the battery should be as short as possible and laid next to each other.

3.2 CONTACTORS

Contactors should be selected based upon on the motor max. operating current and on the configuration.

- The current absorbed by the coil should not exceed 3A.
- Coil suppression is internal to the logic. Do not use contactors with suppression elements connected.
- In the case of contactors using magnetic suppression on the contacts, check polarity as shown on the cap.

3.3 FUSES

- To protect auxiliary circuits use a fuse with max. 6.3A.

- To protect the power unit see diagrams.

The indicated value is the max. permissible value. For special applications or requirements this value can be reduced.

For safety reasons it is recommended to use protected fuses in order to avoid particle dispersion in case of blowout.

3.4 CHOPPER H1DN MECHANICAL DRAWING

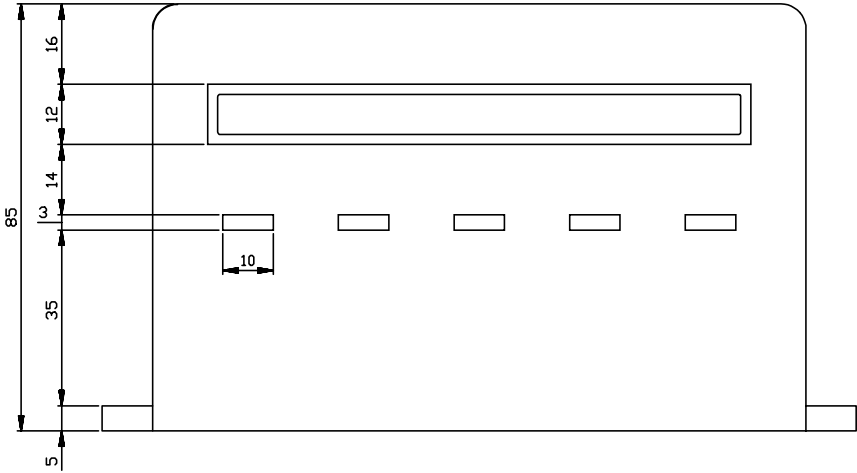
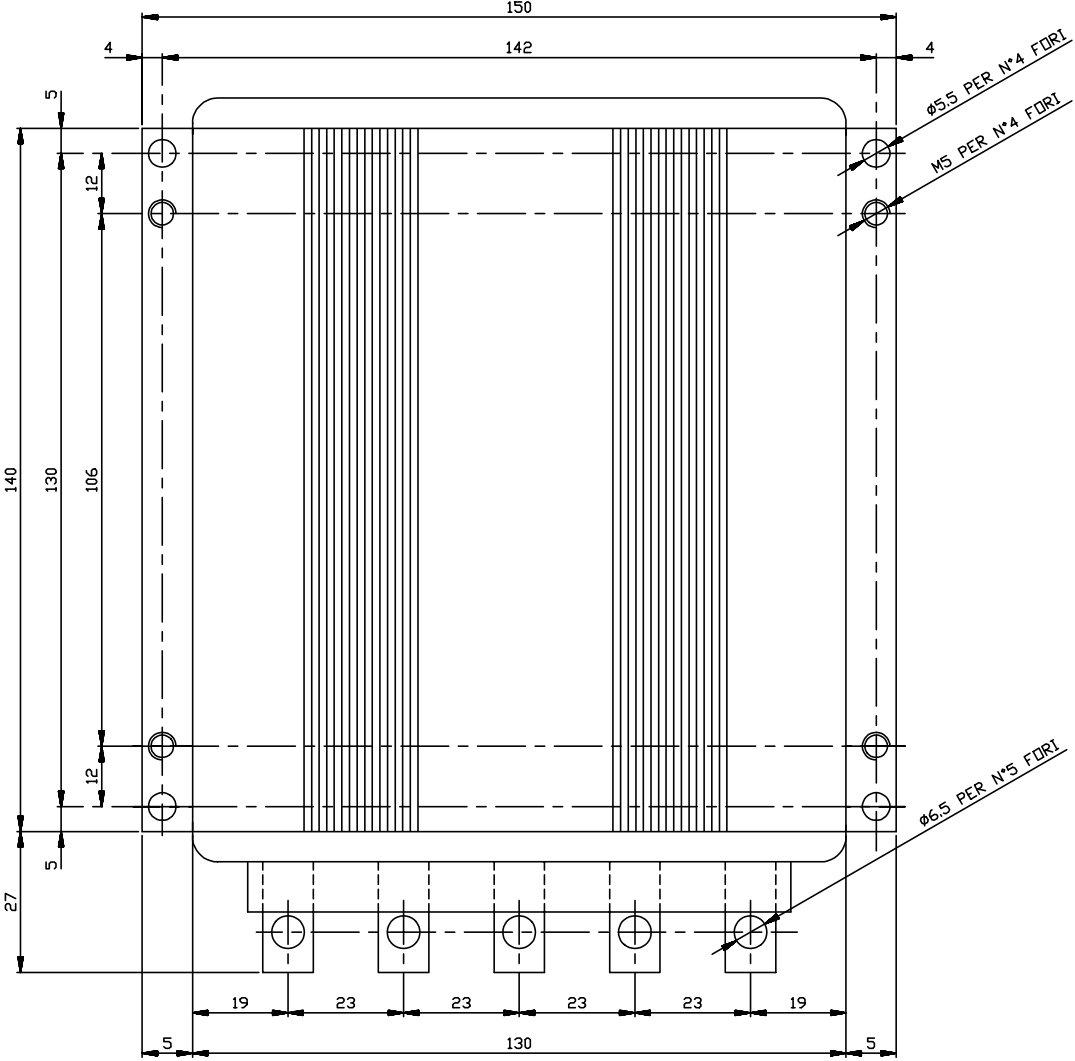

3.5 CONNECTOR DESCRIPTION

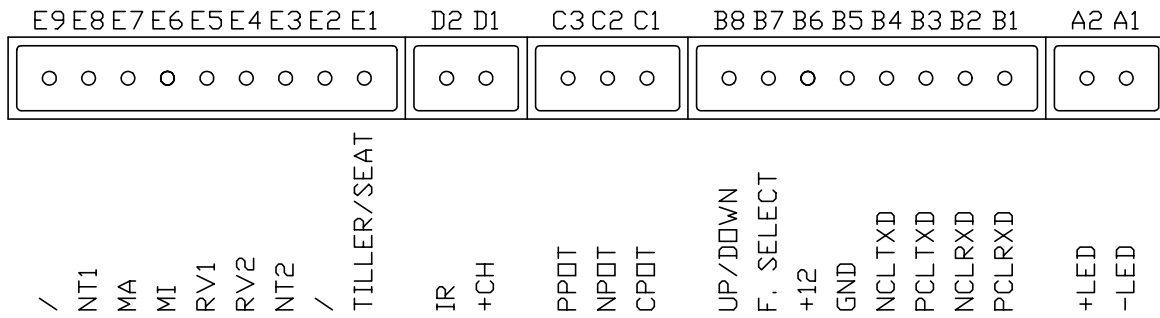

Pos.	Function	Description
A1	LED	Alarm Led minus: to be connected to the cathode.
A2	+LED	Alarm Led plus: to be connected to the anode. Output current 12mA for standard Led.
B1	PCLRXD	Serial reception plus.
B2	NCLRXD	Serial reception minus.
B3	PCLTXD	Serial transmission plus.
B4	NCLTXD	Serial transmission minus.
B5	GND	Console supply minus.
B6	+12	Console supply plus.
B7	FUN. SEL.	Economic console channel.
B8	UP/DOWN	Economic console channel.
C1	CPOT	Potentiometer central: to be connected to the potentiometer slider. For speed adjustment the useful signal ranges from 0Volt (lowest speed) to 5Volt (highest speed).
C2	NPOT	Potentiometer minus: This is a battery negative.
C3	PPOT	Potentiometer plus: This is a 12Volt output. It is not used if the potentiometer is wired with 2 cables. Do not short this terminal to battery negative and do not apply a resistance load of less than 500ohm.
D1	+ Key	To be connected to key switch return.
D2	IR (spare / free)	Signal for handle safety device activation. The safety device is activated with opened microswitch or if the applied voltage is less than 12Volt. If not used it can be wired to Key positive or disconnected from the programmable console.

- E1** TILLER / SEAT Input whose function should be defined from the console (or re
Free requested at the time of order).
Its configuration can be a handle or seat microswitch (5 sec
delayed) signal input; otherwise it can remain unused.
The function is activated if the level is brought to a value greater
than 12Volt.
- E2** // Not used.
- E3** NT2 Energises the field weakening or bypass contactor.
It provides connection to B- 've when active (Max. 3A).
- E4** RV2 Input for speed reduction operation (RV2).
(spare, free) If connected to a potential of more than 12Volts, reduction is
inhibited.
If left free or connected to B-' ve it performs the reduction function
operates. Activation of this input can be programmed from the
console.
- E5** RV1 Input for speed reduction operation (RV1).
(spare, free) If connected to a potential of more than 12Volt reduction is
inhibited while if left free or connected to Battery negative, the
reduction function operates. Activation of this input can be
programmed from the console.
- E6** IN Selects reverse.
It should be connected to the reverse microswitch and activates the
contactor when greater than 12Volts.
- E7** AV Selects forward.
It should be connected to the forward microswitch and activates the
contactor when greater than 12Volts.
- E8** NT1 It operates the main contactor or the running contactors.
When active it provides connection to B-' ve.
- E9** / Not used.

3.6 POWER CONNECTOR DESCRIPTION

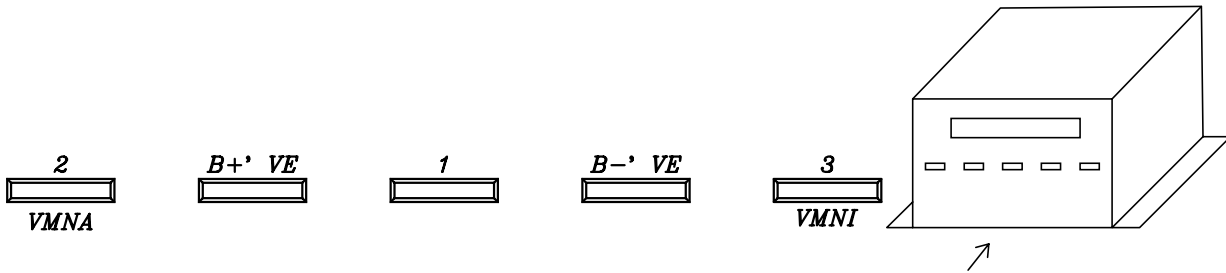

- B +' ve** To be connected to the B+' ve.
It is a power circuit positive which thus does not supply the control logic.
- 1** To be connected to the motor (rotor).
It provides a direct positive from the battery down stream of the current measuring circuit.
Do not connect this terminal to loads other than the traction motor.
- B-' ve** It is connected to the B-' ve.
This feed is also common to the control logic circuit.
- 2** It is the forward direction driver (VMNA).
It supplies a B-' ve via a mosfet circuit when the forward direction is active.
For connections see diagrams.
- 3** It is the reverse direction driver (VMNI).
It supplies a B-' ve via a mosfet circuit when the reverse direction is active.

3.7 DESCRIPTION OF CONNECTIONS

The choices concerning the power unit and some auxiliary signals should be programmed into the chopper.
In the absence of this information the chopper sends an alarm (ALARM 1) and will not operate. To provide this information, simply connect the chopper to the console and enter the specific menu (see console description).
The available standard configurations are as follows:
Power unit configurations programmable from the console.
3 cables with main contactor : max. 150A.
4 cables with remote-control inverter : max. 300A.
Auxiliary inputs with configuration made from the console:

INPUT	STATES SELECTABLE FROM THE CONSOLE
E5	RV1 0 = CUT BACK SPEED 1°, FREE = NOT USED, SPARE = TO BE DEFINED
E4	RV2 = CUT BACK SPEED 2°, FREE = NOT USED, SPARE = TO BE DEFINED
D2	INVERS = RAPID INVERSION, FREE = NOT USED, SPARE = TO BE DEFINED
E1	SEAT = SEAT MICROSWITCH DELAY, HANDLE = HANDLE MICROSWITCH, SPARE = TO BE DEFINED

Depending on the customer's request, the chopper is supplied comes with its configuration and name-plate indicating the model and max. current.

3.8 DIODES

In 1 Quadrant versions for 4 or 3 cable motors external diodes should be fitted to allow for adjustable braking.

Upon customer's request ZAPI will supply the system with a module containing easily connecting diodes both for the 4 cable and 3 cable versions.

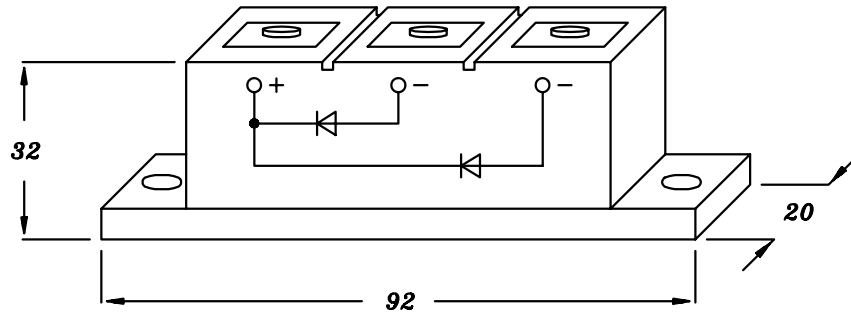

4 CABLES 1 QUADRANT

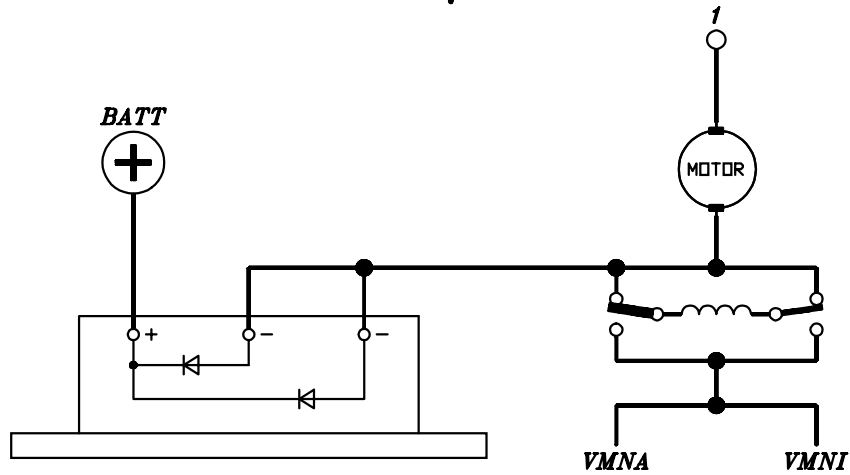

3 CABLES 1 QUADRANT

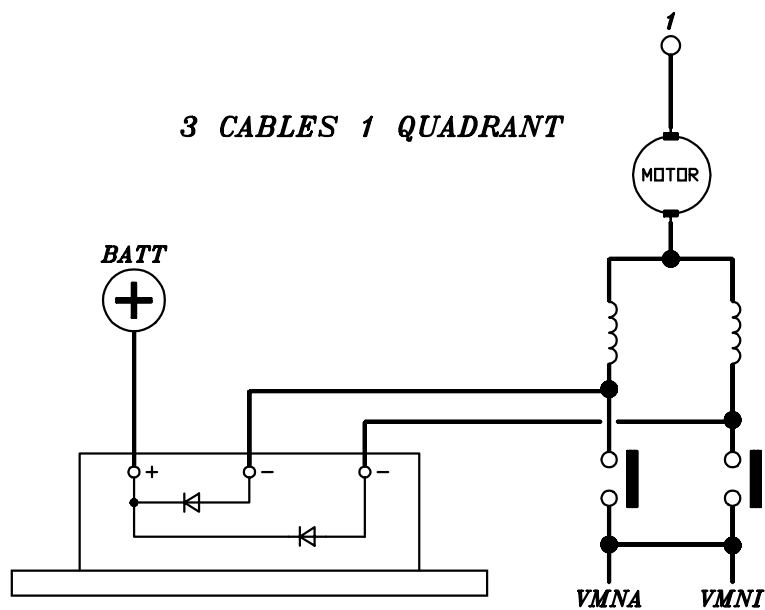

4 SETTINGS

Similarly to chopper configuration, parameter settings can be directly made at ZAPI according to the customer's specifications or by the customer via the programming console or the economic console which allows changes only to the parameters indicated with an asterisk*.

The chopper parameters shown below can be changed between ten intermediate levels within the specified range:

PARAMETER	UNIT	PROGRAMMED LEVEL									
		0	1	2	3	4	5	6	7	8	9
ACCELERATION DELAY*	Sec.	0.38	0.66	1	1.3	1.5	1.84	2.17	2.5	2.8	3
BRAKING (CPOT = MAX)*	% IMax.	50	58	66	73	81	89	96	104	112	120
CUT BACK (1-2)*	% VBatt.	16	20	25.6	34.6	43	48.5	53.5	62.6	65	76
COMPENSATION	K (I)	0	0.1	0.2	0.3	0.4	0.5	0.6	0.7	0.8	0.9
CREEP SPEED*	% VBatt.	2.5	6.9	9.2	11.7	14	16.3	20.8	22	25	30
IMax. 2Q	Amp.	75	83	92	100	108	117	125	133	142	150
IMax. 1Q	Amp.	150	167	183	200	217	233	250	267	283	300
Max. SPEED (F-B)	% VBatt.	7	9.3	20	30	39.2	48.4	60	65	74	CT.
RELEASE BRAKING	% IMax.	-	18	27	36	45	54	63	72	81	90

The console can be kept constantly connected to the chopper and parameters may be changed in real time during operation.

The parameters set and optimized can be recorded via the console (SAVE) and then re-loaded (RESTORE) into another chopper thereby making it possible to obtain rapid and standard settings (see console manual for further details).

The logic unit inside the chopper features a trimmer for adjusting the max. value of the potentiometer if it is connected to 2 wires. To perform setting remove the upper cover, connect a tester for voltage measurement between the CPOT and NPOT connectors, bring the potentiometer control unit to max. stroke and rotate the logic unit trimmer until a voltage of 4.8 - 4.9Volt is read.

With the programming console this operation is made easier in that the value is read directly on the display.

4.1 DESCRIPTION OF VARIABLE PARAMETERS

Acceleration delay	=	Acceleration
Braking	=	Braking
Cut back speed 1	=	Speed 1 reduction
Cut back speed 2	=	Speed 2 reduction
Compensation	=	Compensation
Creep speed	=	Lowest speed (First ramp)
I _{Max.}	=	Max. current
Max. speed forward	=	Highest speed forward
Max. speed reverse	=	Highest speed reverse
Release braking	=	Braking current when direction selector is released.

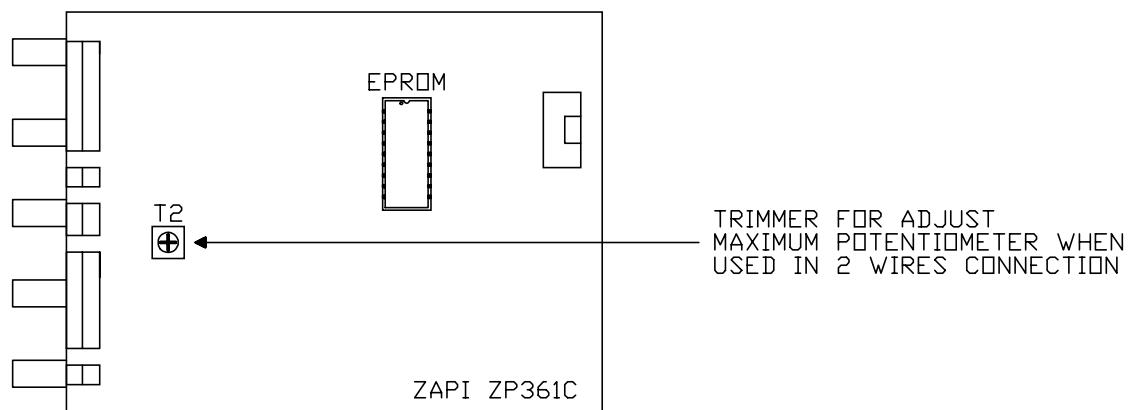

4.2 PARAMETER CHANGE VIA ECONOMIC CONSOLE

The parameters which can be changed are as follows:

- 1 CREEP SPEED
- 2 ACCELERATION DELAY
- 3 BRAKING
- 4 CUT BACK SPEED 1
- 5 CUT BACK SPEED 2
- 0 NOT CONNECTED

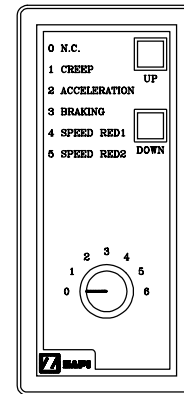

Adjustments are possible within the range specified on Page 19 at 10 intermediate adjustment levels.

- Connect the economic console to the chopper (B) connector (this operation should be performed when the machine is off).
- Reconnect the battery, switch on the machine by turning the key.
- Position the rotating selector to the function requiring change.
By pressing the SET-UP button the parameter value can be increased while pressing the SET-DOWN button the same value can be decreased.
Warning! Changes are made by counting the number of pulses sent by the push buttons. Therefore to increase or decrease one parameter by several points you should release and press the button again as required.
Keeping a push-button continuously pressed does not allow you to obtain continuous parameter variation.
- Parameter variation occurs in real time making it possible to immediately check the set values.

4.3 DESCRIPTION OF DIGITAL CONSOLE FUNCTIONS

- Power configuration : H1DN 3 cables 2Q.
H1DN 4 cables-T 1Q.
- Input configuration : RV1, RV2, IR, SP
- Parameter programming : Acceleration
Braking
Cut back speed 1
Cut back speed 2
Compensation
Creep speed
Max. current
Max. speed forward
Max. speed reverse
Release braking

- Tester : VMNA
VMNI
T1 and T2 driver
IN, AV, RV1, RV2, SP, IR inputs
Accelerator voltage
Current
Temperature
Battery voltage
Motor voltage

- Display of stored alarms
- Internal hour meter
- Accelerator stroke programming, forward and reverse
- SAVE function (data storage)
- Restore function (parameter loading onto a chopper)
- Motor Data

See console manual for details.

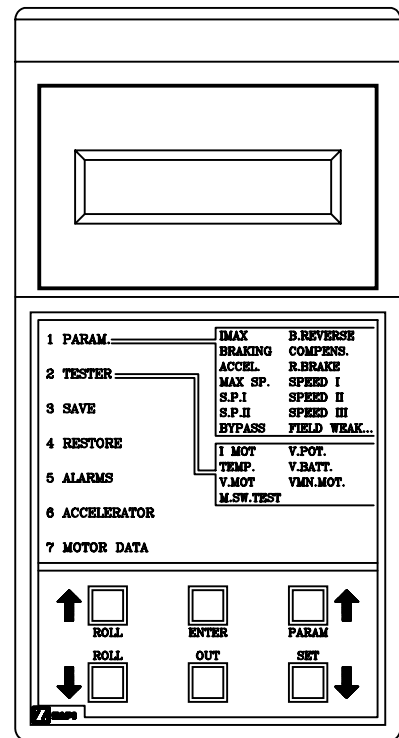

4.4 SEQUENCE OF SETTINGS H1DN

- With the machine switched off, connect the programming console and then switch on. If no wiring errors or component defects are found, the display shows the manufacturer's name, programme release, configuration, and hour-metre value. If the module has already been configured, the procedure passes directly to step two. Otherwise, proceed in order as follows.

Consult the console manual for further procedure details.

- 1) Configure the chopper model.
- 2) Select the desired options.
- 3) Check the functioning of all the wired inputs, including the potentiometer, by means of the tester functions on the console.
- 4) Carry out accelerator signal acquisition on the "PROGRAM VACC" menu.
- 5) Set the maximum current by selecting the level corresponding to the desired value shown on the table of modifications (pages 16).
- 6) Set acceleration by moving the machine forward and backward.
- 7) Set the CREEP speed starting from level 0. With the machine stopped, press the pedal lightly in order to trip the running microswitch, leaving the potentiometer at the minimum value, and then raise the level of the CREEP until the machine begins to move.
- 8) To set the speed reductions, activate the desired reduction request microswitch, take the compensation level to 0, set the speed (CUTBACK SP.I, etc.) with machine in standby on a flat surface and the accelerator pedal pressed all the way down.
Then, apply a load on the machine or put it on a slope, and in these conditions set the compensation level until you reach the desired speed.
- 9) RELEASE BRAKING is set by running the machine and then completely releasing the accelerator pedal without pressing other pedals.
- 10) For BRAKING, run the machine and invert the direction with the pedal pressed down, then regulate the braking level.

5 H1DN DIAGNOSIS

Description of the alarms signalled by the diagnostic LED.

The alarm code is shown in parentheses. A detailed description is given in the section "DECODING THE ALARMS DISPLAYED ON CONSOLE" on page 18÷19.

- 1 BLINK = Logic anomaly (EEPROM DATA KO, EEPROM PAR. KO, EEPROM CONF. KO, EEPROM OFF-LINE, CHOPPER NO CONF, WATCH-DOG).
- 2 BLINKS = Running request on startup or error in handle/speeds sequence (INCORRECT START).
- 3 BLINKS = Error on VMN test (NO FULL COND, VMN BACK LOW, VMN FORW LOW).
- 4 BLINKS = Accelerator high in standby - this error inhibits operation (VACC NOT OK).
- 5 BLINKS = Error in reading current - this error inhibits operation (1 HIGH AT STAND, I=0 EVER).
- 6 BLINKS = Malfunctioning of the contactor driver circuit (CONTACTOR DRIVER).
- 7 BLINKS = Excessive temperature, greater than 75° (TH. PROTECTION).
- 8 BLINKS = Contactors do not close (CONT. DONT CLOSE).
- CONTINUOUS BLINKING (32 BLINKS) = Low battery charge, battery with <10% of residual charge (BATTERY).
- LED REMAINS ON = Double running request (FORW BACK).

5.1 DECODING ALARMS DISPLAYED ON THE CONSOLE

1) CHOPPER NO CONFIG.

This alarm appears if there has not yet been logic unit configuration. In this case apply the model and input configuration procedure as described in the relevant paragraph of the console manual. The alarm is blocking.

2) VMN FORW LOW.

The test is performed at rest. An alarm is sent if VMN forward voltage (terminal 2) is found to be less than 1/3 of battery voltage.

Possible causes:

- a) In 2 Quadrant configurations check that stator cabling is correct and that there are no interruptions.
- b) Check that motor has no frame fault.
- c) In 1 Quadrant configurations with bypass check that bypass contacts are not welded close.
- d) Chopper out of order, replace.

3) VMN BACK LOW.

See Item 2.

4) NO FULL COND.

The test is performed under full conduction.

If in this condition it turns out that VMN is more than 1/3 of battery voltage something is wrong in the diagnostics circuit thus impairing safety. For this reason the machine stops operating.

If this fault persists replace the logic unit.

5) CONT. DONT CLOSE

This test is performed with an operating request.

It should be checked that the contactor closes and that VMN is greater than 2/3 of the battery voltage. If not an alarm is sent.

Possible causes:

- a) Main or running contactor disconnected or faulty, isolated contacts.
- b) Isolated or interrupted motor.
- c) Chopper power unit failure, replace.

6) I=0 EVER

This test is performed during operation.

It should be checked that current during operation is greater than a minimum given value. If this is not the case an alarm is displayed and the machine stops.

Possible causes:

- a) Incorrect motor connection. For example, the rotor may have been connected to the chopper (+B) terminal instead of terminal (1).
- b) The current sensor has failed, replace power unit.

7) I HIGH AT STAND

This test should be performed at rest. It should be checked that current is equal to zero. If this is not the case an alarm is displayed and the machine stops.

Possible causes:

- a) Terminal (1) has been connected to a load other than the driving motor, e.g. to the pump motor or auxiliary loads.
- b) The current sensor or the logic unit may have failed.
Replace the logic unit first. If faulty operation persists change the power unit.

8) WATCH-DOG

This test is performed both at rest and during operation.

It is self-diagnosing within the logic unit.

Replace the logic unit in case an alarm is displayed.

9) FORW-BACK

This test is always performed. An alarm is displayed if two running requests are simultaneously available.

Possible causes:

- a) Faulty cabling
- b) Failed running microswitch
- c) If faulty operation persists replace the logic unit.

10) INCORRECT START

Incorrect starting sequence.

The machine starts only if the key - handle (or seat) - run sequence is followed.

Possible causes:

- a) Failed running or handle microswitch.
- b) Incorrect operator's sequence.
- c) Incorrect cabling.

11) VACC NOT OK

This test is performed at rest.

The alarm shows that the accelerator voltage is greater than 1 Volt.

Possible causes:

- a) One potentiometer wire has become disconnected.
- b) The potentiometer is not calibrated.
- c) The potentiometer is faulty (interrupted).

12) CONTACTOR DRIVER

This test is performed both at rest and during operation. It should be checked that the voltage on the drivers which control contactors is in line with the running state.

High at rest, low during running. With the console tester function check which driver, whether T1 or T2, is in the correct running (Ø) or resting (1) state.

Possible causes:

- a) External short-circuit towards -Batt of the cabling coming from NT1 or NT2.
- b) Driver failure due to overloading or short-circuit to +Batt of the cabling from NT1 or NT2. Replace the logic unit after performin troubleshooting.

13) EEPROM DATA KO

Failure in the memory area which contains the hour meter and motor data as well as the stored alarms. The alarm is blocking.

When switching the key on and off, if the alarm is still displayed replace the logic unit.

If the alarm disappears please remember that the hour meter starts again from zero, the alarm area is cancelled and the motor data contains default data.

14) EEPROM PAR.KO

Failure in the memory area which contains the setting parameter data.

The alarm is blocking.

When switching the key on and off, if the alarm is still displayed replace the logic unit. If the alarm disappears please remember that the hour meter starts again from zero, the alarm area is cancelled and the motor data contains default data.

15) EEPROM CONF.KO

Failure in the memory area which contains the data for chopper configuration.

The alarm is blocking. Move to the configuration phase and perform chopper re-configuration.

Subsequently switch off and on again. If the failure persists replace the logic unit.

16) EEPROM KO

Failure in the memory chip. Replace the logic unit.

The alarm is blocking.

18) TH PROTECTION

It indicates that chopper temperature has exceeded 75°C.

Max. current is progressively reduced until a zero value is reached at the temperature of 85°C.

If the alarm is displayed while the machine is in cold state:

- a) Check thermal sensor connection
- b) Faulty thermal sensor
- c) Interrupted power unit connection
- d) Faulty logic unit

19) BATTERY

Battery is dis-charged.

When the alarm is displayed the machine stops. At this stage start again with renewed running request.

Max. current is reduced by 50%.

6 SCHEMATIC DIAGRAMS

6.1 DESCRIPTION OF H1DN 3 CABLES 2Q LAYOUT

Configuration with console:

Select the model 3C:

PIN SELECTION	DIS. 072395B	DIS. 072398B
5E	RV1	RV1
4E	RV2	RV2
2D	INVERS	INVERS (FREE SE IR NON COLLEGATO)
1E	HANDLE	SEAT
3E	FREE	FREE

Characteristics:

Max. current 150A.

Static change of the running direction.

The main contactor closes the first time that there is a 4 operating request and opens when the handle is at rest.

Speed cut-backs are active when microswitches are open.

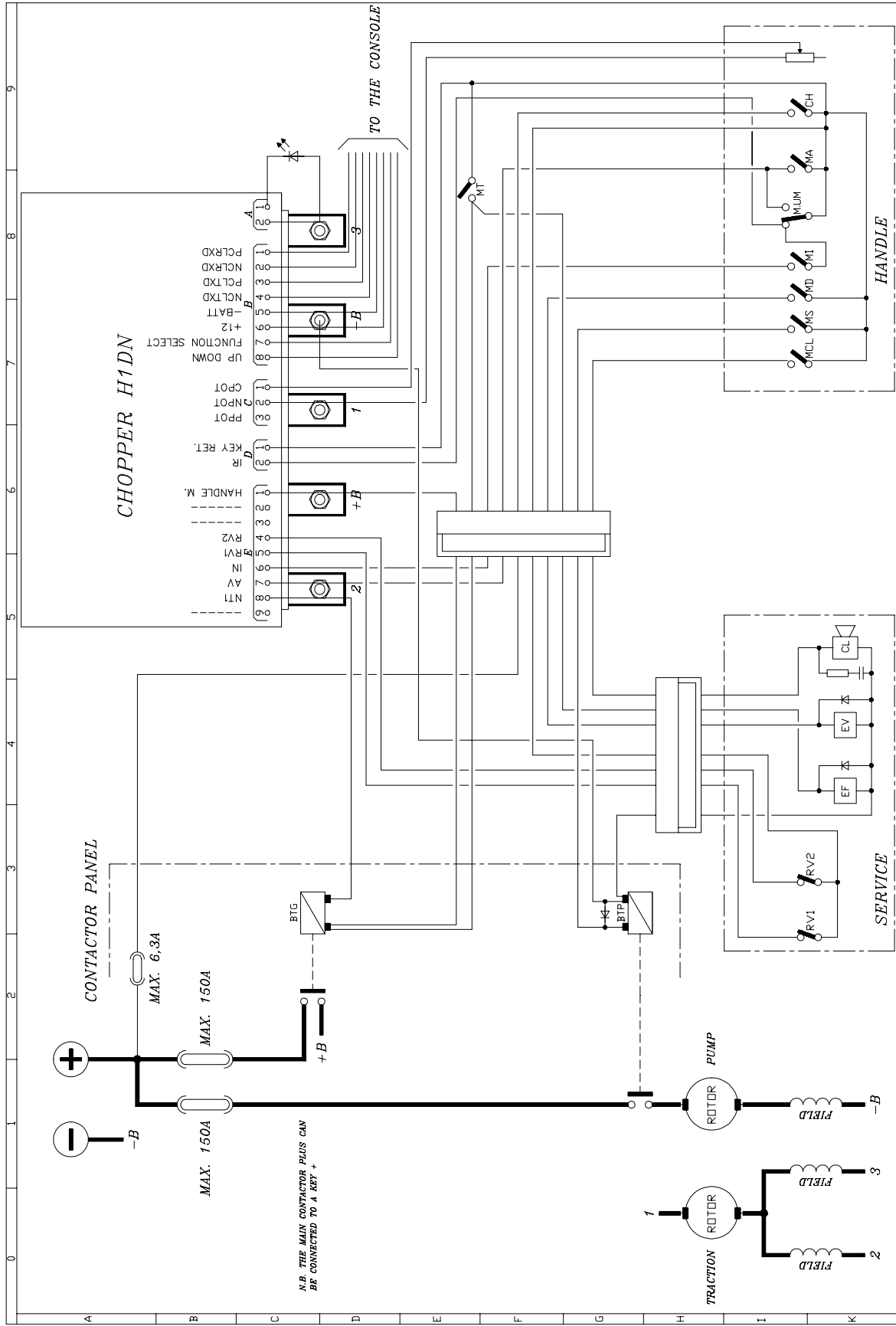

THIS DRAWING IS A ZAPF S.p.A. PROPERTY. ITS REPRODUCTION IS PROHIBITED EXCEPT FOR A WRITTEN AUTHORIZATION. THE ONLY ALLOWED USE IS THAT RELATIVE TO THE REPAIRS OF ZAPF PRODUCTS.

S.p.A. 41028B POVIGLID - ITALY	Data Tecnico L.C. 26/07/93 visto	Simbolo GHF	Disegno n. 072395B	Pagina n.
-----------------------------------	--	----------------	-----------------------	-----------

CONNECTION DIAGRAM OF H1 - 3 CABLES 2Q (TILLER)

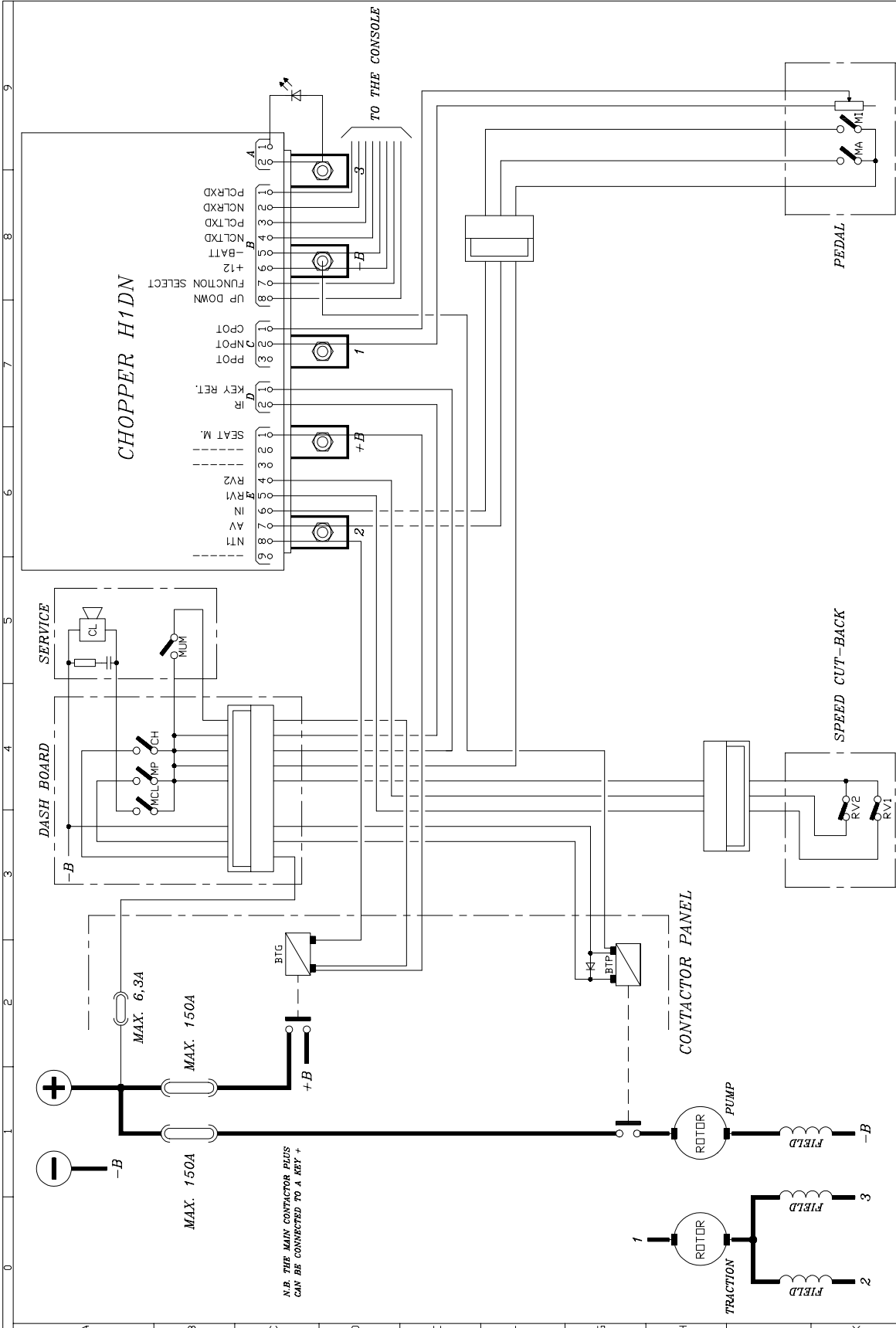

THIS DRAWING IS A ZAPF S.p.A. PROPERTY. ITS REPRODUCTION IS PROHIBITED EXCEPT FOR A WRITTEN AUTHORIZATION. THE ONLY ALLOWED USE IS THAT RELATIVE TO THE REPAIRS OF ZAPF PRODUCTS.

ZAPF S.p.A. - 42068 PIVULI (MO) - ITALY

Da: Tecnico LC

Visto: 03/03/93

Disegno n. 072398B

Serie GHF

Page n. 2

CONNECTION DIAGRAM OF H1D - 3 CABLES 2Q (PEDAL)

6.2 HIDN AUTOSTOP

Standard HIDN performs release braking function. This mean that when throttles or the pedal is released the HIDN chopper performs a braking with a reverse flowing current. The intensity of this brakaking is adjustable by the RELEASE BRAKING parameter in the consolle. By setting the RELEASE BRAKING parameter at zero the Atostpo function is not performed, therefore the chopper behavies as a standard controller (with no auto-stop function).

6.3 DESCRIPTION OF H1DN 4 AND 3 CABLES 1Q LAYOUT

Configuration with consolle:

Select the model: 4C-T.

PIN SELECTION	DRWG. 072399B	DRWG. 072400B	DRWG. 072445B	DRWG. 072446B
5E	RV1	RV1	RV1	RV1
4E	RV2	RV2	RV2	RV2
2D	INVERS	FREE	INVERS	FREE
1E	HANDLE	SEAT	HANDLE	SEAT
3E	BY. PASS	BY. PASS	/	/

Characteristics:

Max. current 300A.

Running direction is changed only via the contactors.

Braking diodes should be fitted as per diagram in order to obtain chopper-controlled braking.

Speed cut-backs are active when microswitch contacts are open.

When throttle or pedal is released the HIDN chopper performs a braking with a reverse flowing current. The intensity of this brakaking is adjustable by the RELEASE BRAKING parameter in consolle. The AUTOSTOP braking can be performed if the motor reaches a certain minimum speed.

In the 3-cable version the power interconnections should be modified as shown in drawings #'s 072399B & 072400B.

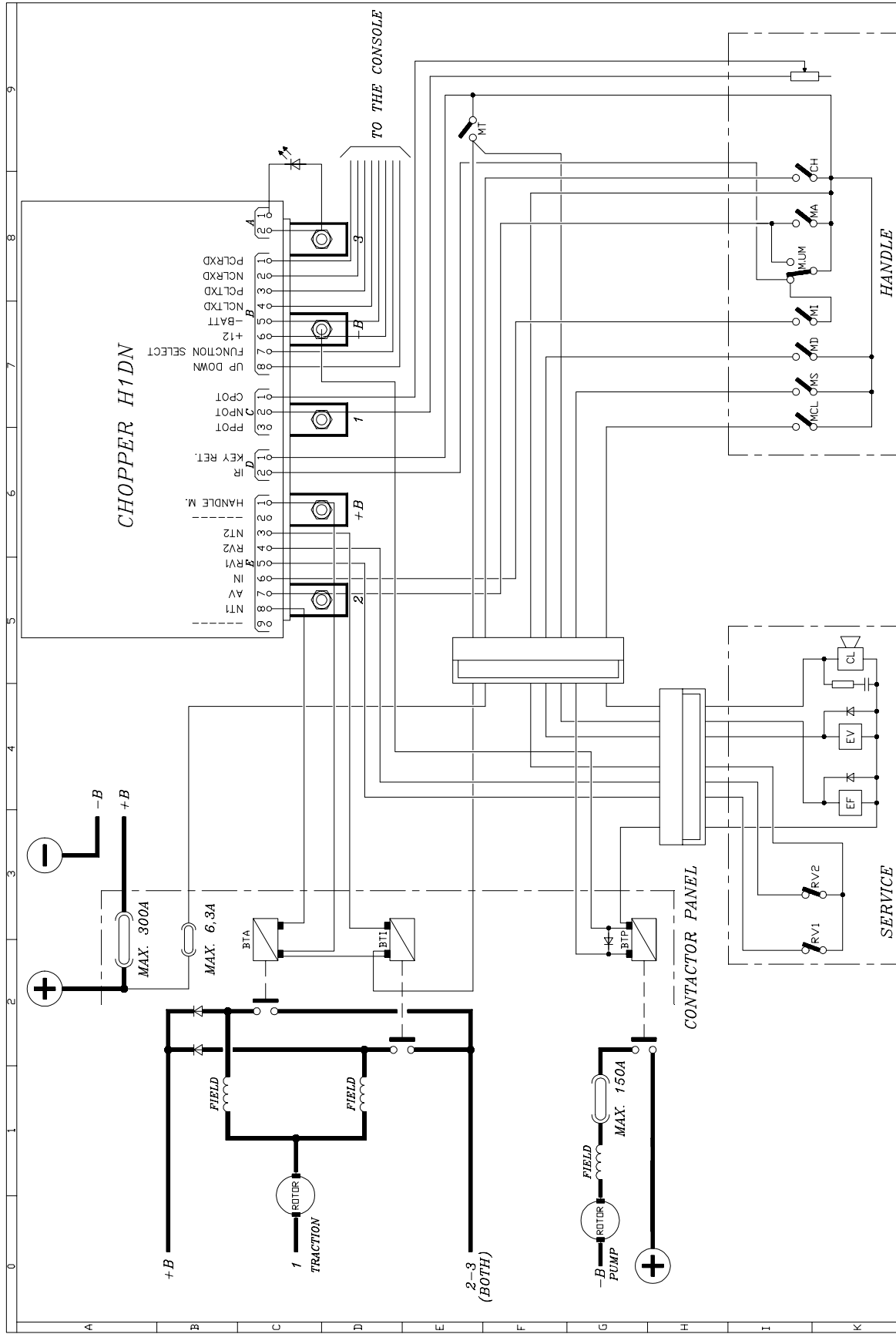

THIS DRAWING IS A ZAPF S.p.A. PROPERTY. ITS REPRODUCTION IS PROHIBITED EXCEPT FOR A WRITTEN AUTHORIZATION. THE ONLY ALLOWED USE IS THAT RELATIVE TO THE REPAIRS OF ZAPF PRODUCTS.

ZAPF S.p.A. Data
 34028 PORDOLGO - ITALY 02/03/93 Visto
 Tecnico LC

CONNECTION DIAGRAM OF H1 - 3 CABLE 10 (TILLER)

Serie GHF

Disegno n. 072399B

Pagina n.

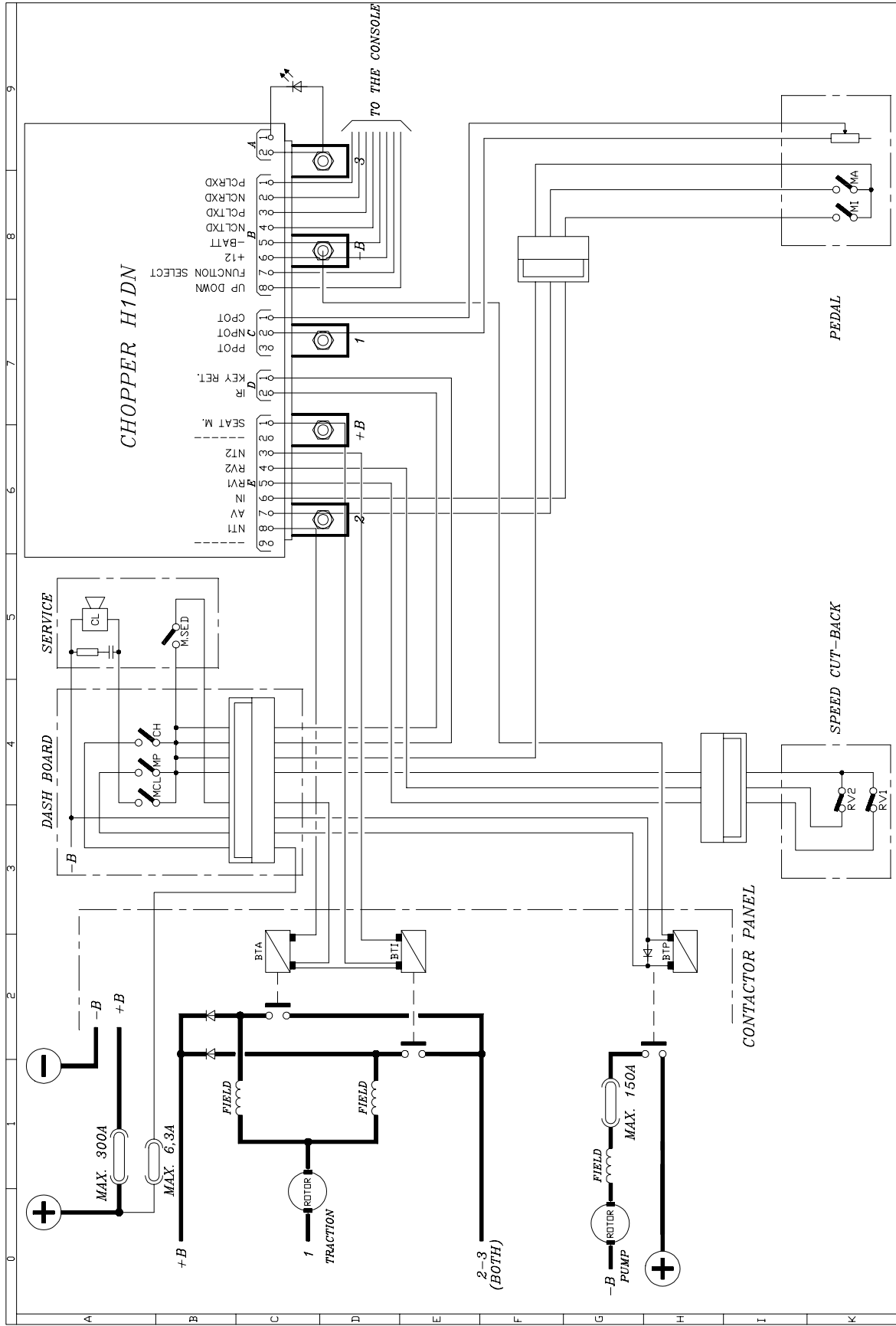

THIS DRAWING IS A ZAPF S.p.A. PROPERTY. ITS REPRODUCTION IS PROHIBITED EXCEPT FOR A WRITTEN AUTHORIZATION. THE ONLY ALLOWED USE IS THAT RELATIVE TO THE REPAIRS OF ZAPF PRODUCTS.

ZAPF S.p.A. Bat. Tecnico L.C. 02/03/93 Visto
 42088 POMEZIA (PV) - ITALY

Design n. 072400B
 Serviz. GHF
 Pagina n.

CONNECTION DIAGRAM OF H1D - 3 CABLES 1Q (PEDAL)

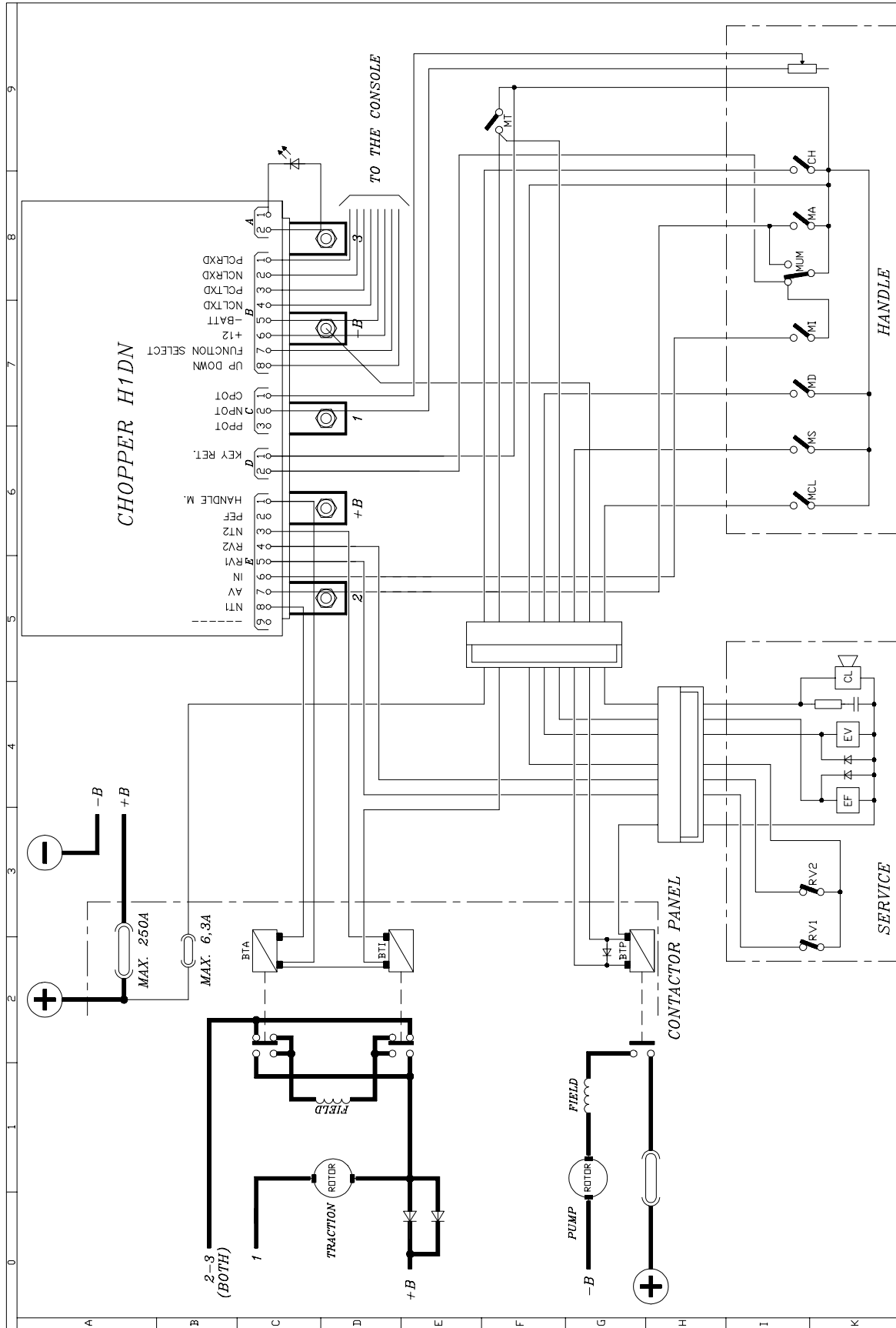

THIS DRAWING IS A ZAPF S.p.A. PROPERTY. ITS REPRODUCTION IS PROHIBITED EXCEPT FOR A WRITTEN AUTHORIZATION. THE ONLY ALLOWED USE IS THAT RELATIVE TO THE REPAIRS OF ZAPF PRODUCTS.

S.p.A. Data Tecnico AC
 40068 PDV/ITALIA - ITALY 02/03/93 Visto

Serie GHF Disegno n. 072445B
 Pagina n.

CONNECTION DIAGRAM OF H1 - 4 CABLES WITH CHANGEDOVER CONTACTORS IQ (TILLER)

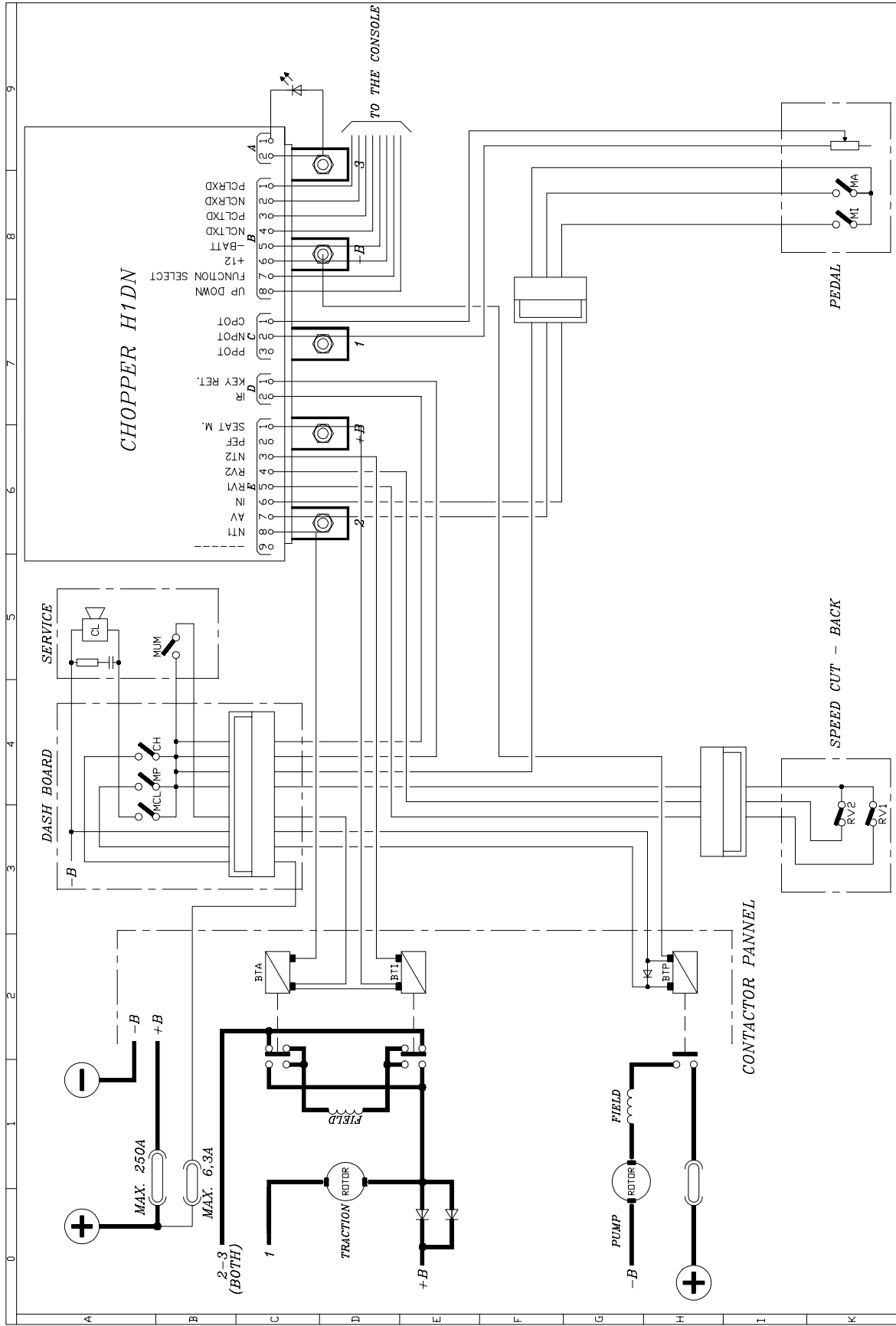

THIS DRAWING IS A ZAPF S.p.A. PROPERTY. ITS REPRODUCTION IS PROHIBITED EXCEPT FOR A WRITTEN AUTHORIZATION. THE ONLY ALLOWED USE IS THAT RELATIVE TO THE REPAIRS OF ZAPF PRODUCTS.

ZAPF S.p.A. Batù Tecnico AC
 420288 PDV1014D - ITALY 03/03/93 Visto

Connection Diagram of H1D - 4 Cables with Changeover Contactors 1Q (PEDAL)
 Service: GHF
 Design n.: 072446B
 Pagina n.:

RECCOMENDED SPARE PARTS

<i>Code</i>	<i>Description</i>
E07008	Potentiometer 5 kohm 25°
C22000	Microswitch 10A 250V 1-way
C16504	Protected power fuse 300A
C16530	Protected power fuse 250A
C16503	Protected power fuse 200A
C16502	Protected power fuse 160A
C16520	Glass 5x20 fuse 6.3A
C16530	Protected power fuse 250A
C12373	9-way molex female connector
C12371	3-way molex female connector
C12370	2-way molex female connector.
C12769	Female connector (molex)
C12204	9-way female lock connector
C12203	6-way female lock connector
C12205	4-way female lock connector
C12768	Male connector (for female lock)
C12230	9-way male lock connector.
C12229	6-way male lock connector.
C12228	4-way male lock connector.
C12767	Female connector (for male lock)
C29520	Albright contactor 24V SW 88-1
C29548	Albright simple contactor 24V SW 80 B-1

PERIODIC MAINTENANCE TO BE REGULARLY REPEATED

Check outwear of electric contacts: they should be replaced when matchboard is too strong and wornout. **Electric contacts should be checked every 3 months.**

Check pedal microswitch: verify with a tester that there is no electric resistance between the contacts by measuring the voltage drop between its terminals. Also the release should have a firm sound. **The pedal microswitch should be checked every 3 months.**

Check motor-battery power links: they should be in excellent shae as well as the wires' claddings. **Wires should be checked every 3 months.**

Control of the pedal and contactors springs. They should be able to extend to its full extention and **checked every 3 months.**

Check contactors mecanical movements. They should be frictionfree and not stick. **Mechanical movements of the contactors should be checked every 3 months.**

CHECKS SHOULD BE DONE BY SKILLED PERSONNEL ONLY AND, ALL SPARE PARTS SHOULD BE ORIGINAL.

INSTALLATION OF THIS ELECTRONIC CONTROLLER SHOULD BE DONE ACCORDING TO THE DIAGRAMS INCLUDED IN THIS MANUAL AND ANY VARIATION SHOULD BE DONE ACCORDINGLY WITH THE SUPPLIER. THE SUPPLIER IS NOT RESPONSIBLE FOR ANY PROBLEM THAT ROSE FROM USING WIRING SOLUTIONS DIFFERENT FROM THE ONES SUGGESTED ON THIS MANUAL.

**DO NOT USE A VEHICLE WITH A
FAULTY ELECTRONIC CONTROLLER**



COSTRUZIONE APPARECCHIATURE ELETTRONICHE - OLEODINAMICHE - INDUSTRIALI

42028 - POVIGLIO - (R.E.) Via Parma, 59 - ITALIA

Tel. (0522) 960050 (r.a.) - Tlx. 530021 AINDRE I - Fax (0522) 960259

ZAPIMOS H1DN

USER's MANUAL

