



ZAPI[®] S.p.A.

**ELECTRONIC • OLEODYNAMIC • INDUSTRIAL
EQUIPMENTS CONSTRUCTION**

Via Parma, 59 – 42028 – POVIGLIO (RE) – ITALY
Tel +39 0522 960050 (r.a.) – Fax +39 0522 960259
e-mail: zapi@zapispa.it – web: www.zapispa.it

EN

User Manual

MDI-CAN

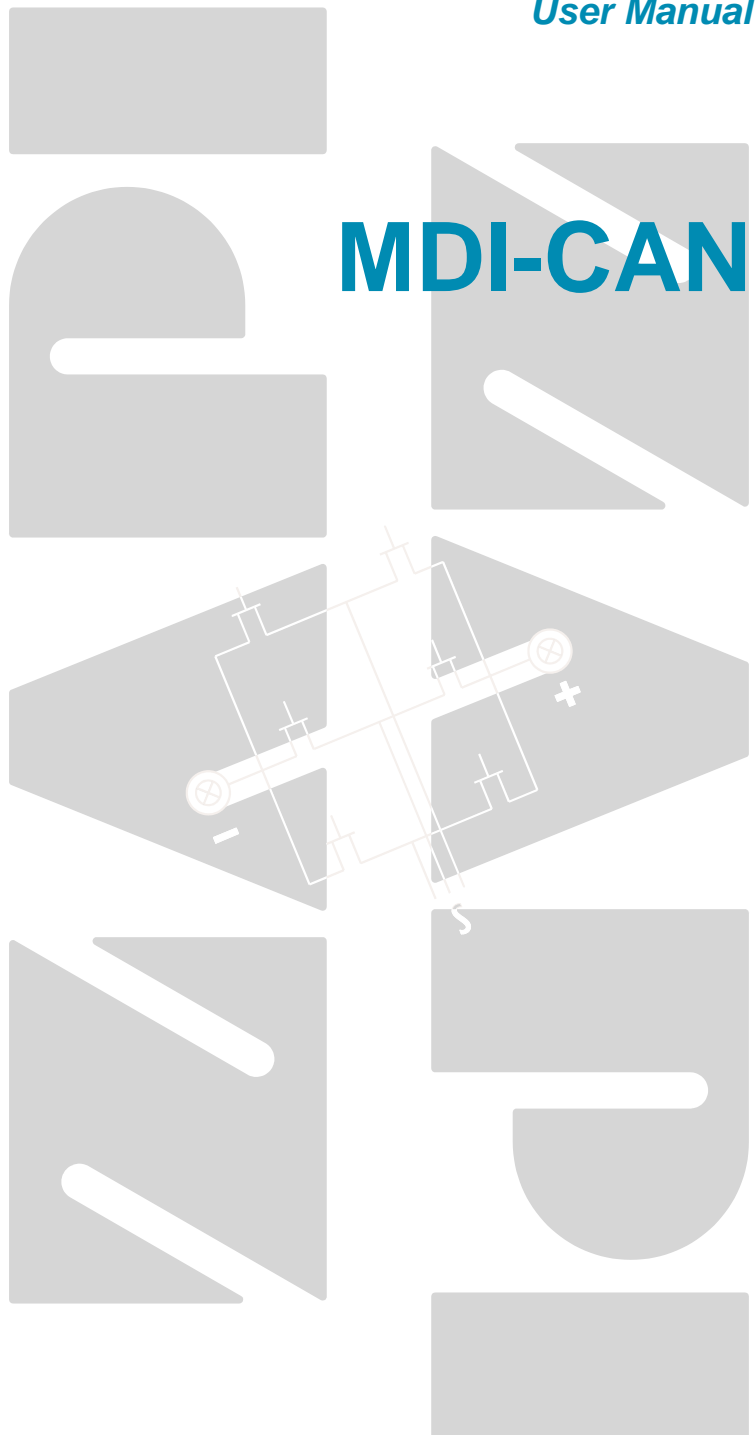

The contents of this publication is a ZAPI S.p.A. property; all related authorizations are covered by Copyright. Any partial or total reproduction is prohibited.

Under no circumstances will Zapi S.p.A. be held responsible to third parties for damage caused by the improper use of the present publication and of the device/devices described in it.

Zapi spa reserves the right to make changes or improvements to its products at any time and without notice.

The present publication reflects the characteristics of the product described at the moment of distribution. The publication therefore does not reflect any changes in the characteristics of the product as a result of updating.



ZAPI® is a registered trademark property of Zapi S.p.A.

NOTES LEGEND



The symbol aboard is used inside this publication to indicate an annotation or a suggestion you should pay attention.



The symbol aboard is used inside this publication to indicate an action or a characteristic very important as for security. Pay special attention to the annotations pointed out with this symbol.

Contents

1	FEATURES.....	4
1.1	Specifications.....	4
1.2	Functional descriptions.....	5
1.2.1	LED function.....	5
1.2.2	Display function.....	5
2	INSTALLATION.....	7
2.1	Connection scheme.....	7
2.2	Dimensions.....	8
2.3	Connector description.....	9
3	HOUR-METER MEMORY SERVICE.....	10
4	ALARMS.....	11
4.1	Decoding of the alarms displayed on the MDI-CAN.....	11

APPROVAL SIGNS

COMPANY FUNCTION	INIZIALS	SIGN
GRAPHIC AND LAYOUT	FF	
PROJECT MANAGER	FG	
TECHNICAL ELECTRONIC MANAGER VISA	PP	
SALES MANAGER VISA	PN	

Publication N°: **AEZZP0CB**
Edition: **July 2007**



This manual describes the new MDI-CAN with the Can bus termination resistance wich can be connected through an external jumper applied between CNA-5 and CNA-6. See also chapter 2.3 for the pin description.

1 FEATURES

1.1 Specifications

- ZAPI MDI-CAN is an indicator suitable for every type of battery powered vehicle equipped with a high frequency traction controller from Zapimos family.
- ZAPI MDI-CAN communicates with controllers directly by CAN-BUS.
- It is available also a serial link communication version which is point to point connected with a Zapi controller through the serial interface. See Chapter 2.3 for the pin description.
- This Unit is supplied directly from the chopper and not by the battery. In this way the same device can be used on systems with different battery voltages.
- The battery's state of charge is obtained with an advanced algorithm made by the microprocessor. This algorithm considers the condition of braking or large acceleration current demands from the drive motor.
- Using the Zapi PROGRAMMING CONSOLE, it is possible to make a selection from 100 different types of discharge curves.
- ZAPI MDI-CAN is a microprocessor based system that allows high precision, reliability and adaptability in the measurement of the battery's state of charge, and in the calculation of the hours worked.
- The ZAPI MDI-CAN indicator has three internal functions:
 - Indication of the battery's state of charge
 - Operating hour meter
 - Indication of the system Alarms.
- As this unit is not connected directly to the battery, the ZAPI MDI-CAN does not require the complex auxiliary wiring associated with traditional indicators. The wiring is "point-to-point" (from the indicator directly to the chopper). In this way, the wiring of the machine is simpler, with reduced costs and installation time.

1.2 Functional descriptions

1.2.1 LED function

The MDI-CAN has only a LED. This LED is red and lights and blinks when an alarm is present.

1.2.2 Display function

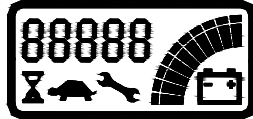

Hour meter

An alpha-numeric liquid crystal display is fitted in the centre of the unit that shows the Hours Worked. The display is backlight (the backlight is normally lighted).

Alarms

The same display can also indicate the Alarm state, showing a Code corresponding to the type of Alarm. To attract attention, the Red LED will start blinking when an Alarm is generated.

Software version

When the Key Switch is initially closed, the display shows the Eprom Version for a few seconds (EPXXX where XXX represents the version): MDI-CAN and then traction controller Eprom Version appears, each one for 2 seconds. Simultaneously the symbol of a Monkey Wrench appears.

Battery State of charge

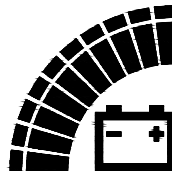

The battery's State of Charge indication is integrated in the LCD display; it is shown by ten notches. Each notch represent the 10% of the battery charge. As the battery becomes discharged, the notches turn off progressively, one after the other, in proportion to the value of the residual battery charge. This value, sent to the MDI-CAN by the controller via CAN-BUS, is displayed in the Tester Menu of the Zapi Console connected to the controller. When BATTERY LOW alarm appears on the controller, the battery symbol which is under the notches blinks.

Other information

Three symbols inform the operator as follows:

Turtle Symbol:



It is normally off; when it appears (fixed) it shows activation of the "soft" mode of

the truck, in which maximum speed and acceleration are reduced;

Monkey Wrench Symbol:



It is normally off; when it appears (fixed) it shows the request of programmed maintenance or the Alarm state. In this case the relative code will be displayed. The information supplied by the MDI-CAN can be extremely useful. Failures can be quickly identified by the Operator or Service Technician thereby finding the fastest solution to the problem.

Hourglass Symbol:



It is normally off; it blinks when the Hour Meter is working.



When the Key Switch is closed, the MDI-CAN makes a general test lighting all the display liquid crystals, the led and the backlight.

In this paragraph and in the following paragraphs the display behaviour if the ZAPI MDI-CAN adopts the standard protocol is described. The ZAPI MDI-CAN can also use a not standard protocol. The traction controller decides which of the two protocols use. If the not standard protocol is used, the traction controller decides how to manage icons, LED, backlight and which information write in the MDI-CAN memory.

2 INSTALLATION

2.1 Connection scheme

REF.	DESCRIPTION
1	PLASTIC CASE
2	FIXING BRACKET
3	GASKET CONNECTOR
4	MOLEX MINI FIT CONNECT. 6 PIN RECEPT. (5557), WITH FEMALE CRIMP TERMINALS (5556)
5	FIXING BOLT
6	RUBBER CAP
7	MACHINE WIRING

NOTE: THE REF. 4 - 5 - 6 - 7 ARE CUSTOMER HARNESS

DESCRIPTION 6 PIN CONNECTOR MDI CAN
(MALE CRIMP TERMINALS)

POS.1 +12V
POS.2 GND
POS.3 CANL/NCLTXD
POS.4 CANH/PCLTXD
POS.5 CANT/PCLRXD
POS.6 CANHT/NCLRXD

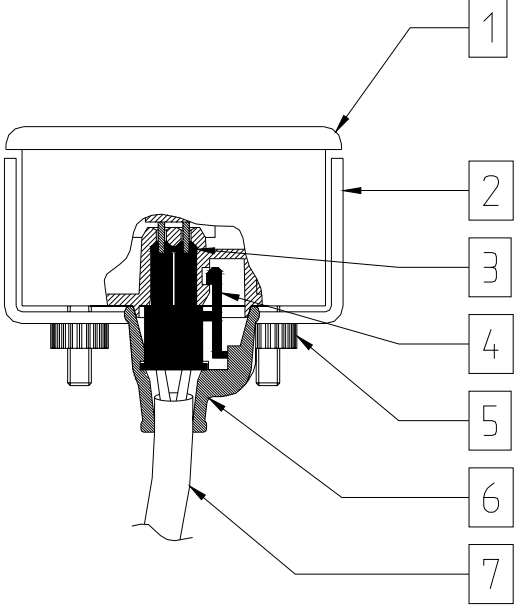

 **HOURMETER**

 **SPEED REDUCTION**

 **MAINTENANCE ALARMS**

88888 ALARMS/HOURS

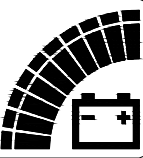
 **BATTERY CHARGE**

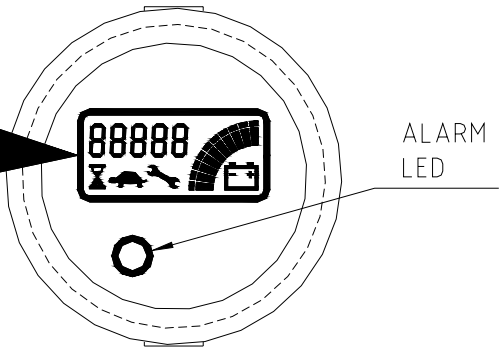

ALARM LED

WIRING DIAGRAM MDI CAN

	Data/Date	Tecnico/Technician	FF	Disegno N./Drawing N	Serie/Series	Pag./Page
	03/07/07	Visto/Visa		AEZZP40C	IND	11

THIS DRAWING IS A ZAPI s.p.a. PROPERTY. ITS REPRODUCTION IS PROHIBITED EXCEPT FOR A WRITTEN AUTHORIZATION. THE ONLY ALLOWED USE IS THAT RELATIVE TO THE REPAIRS OF ZAPI PRODUCTS.

2.2 Dimensions

REF.	DESCRIPTION
1	PLASTIC CASE
2	FIXING BRACKET
3	GASKET CONNECTOR
4	MOLEX MINI FIT CONNECTOR 6 PIN RECEPTACLE (5557), WITH FEMALE CRIMP TERMINALS (5556)
5	FIXING BOLT
6	RUBBER CAP
7	MACHINE WIRING

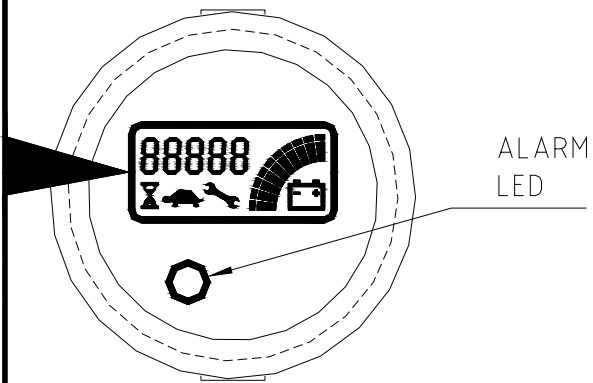
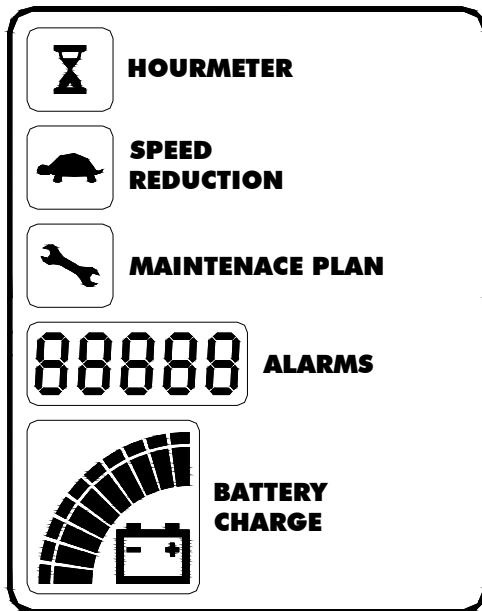
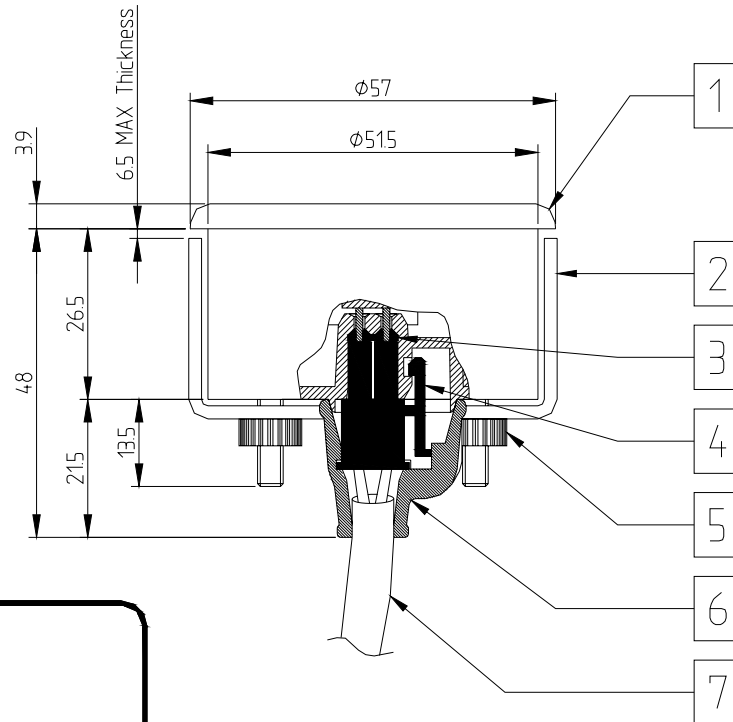

UNITA' di MISURA LINEAR UNIT mm
 SCALA: 1:1

MDI-CAN DIMENSIONS



Data/Date
21/05/05

Tecnico/Technician AC
Visto/Visa

Disegno N./Drawing N.
AEZZP73A

Serie/Series
IND

Pag./Page
11

THIS DRAWING IS A ZAPI s.p.a. PROPERTY. ITS REPRODUCTION IS PROHIBITED EXCEPT FOR A WRITTEN AUTHORIZATION. THE ONLY ALLOWED USE IS THAT RELATIVE TO THE REPAIRS OF ZAPI PRODUCTS.

2.3 Connector description

CNA connector: Molex Minifit

- CANBUS communication version

A1	+12V	MDI CAN positive power supply
A2	GND	MDI CAN negative power supply
A3	CANL	Can Low signal.
A4	CANH	Can High signal.
A5	CANT	A 120 ohm CANBUS termination resistance is connected between this pin and CANL. To connect this pin to CNA#6 to insert the resistance.
A6	CANHT	Internally short circuited to CANH. To connect this pin to CNA#5 to insert the 120 ohm termination resistance.

- SERIAL communication version

A1	+12V	MDI CAN positive power supply
A2	GND	MDI CAN negative power supply
A3	NCLTXD	Serial Transmission negative.
A4	PCLTXD	Serial Transmission positive.
A5	PCLRXD	Serial Reception positive.
A6	NCLRXD	Serial Reception negative.

3 HOUR-METER MEMORY SERVICE

The MDI-CAN indicator retains the Hour Meter value in its own memory (EEPROM). In this way it is possible to transfer the machine hour meter value into other controllers, if a replacement is required, without loss of the hour meter record for a particular machine.

This can be achieved as follows:

- With the key Switch open, connect the ZAPI Console to controller.
- Close the key Switch. Set the function "LOAD HM FROM MDI" to ON. This can be found in the ADJUSTMENTS Menu. In some versions, this function may be called "AUX FUNCTION1".
- Open and close the key Switch.

The replacement controller will now receive and retain the machine hour meter value of the previous controller.

It has to be considered that:

- On default, the parameter "LOAD HM FROM MDI" is set to OFF. Therefore if this type of function is not activated as described above, the memory of the hour-meter will be lost at turn on.
- To avoid this situation, if the operator forgets to set parameter, the MDI-CAN signals the alarm "A98" for 1 minute (during this time traction is disabled). This alarm warns the operator of the imminent cancellation of the hour meter memory. After 1 minute, if the operator has not intervened, the hour meter of the MDI-CAN will be re-written, with the hour meter value of the new controller (Zero Hours if the controller is new).

4 ALARMS

The ZAPI MDI-CAN gives indication of the Alarms of the controllers to which it is connected via CAN-BUS, with a corresponding code.

When an Alarm is generated, the Red LED blinks to attract the attention of the operator. The symbol of Monkey Wrench also appears. The string shown on the display is XXAYY, where XX and AYY represent respectively the alarmed node and the alarm code. The alarm code meaning must be present in the controller user manual.

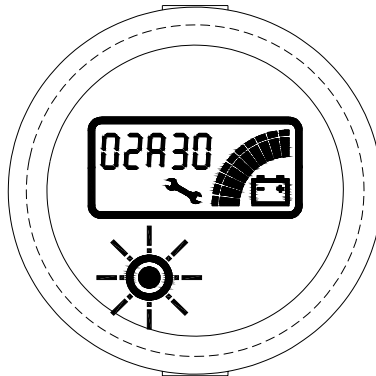

4.1 Decoding of the alarms displayed on the MDI-CAN

Using the indication given by the MDI-CAN and after reference to the following table, the operator can solve the problem, if the failure is not serious. It will also be necessary to refer to the paragraph describing the Alarms in the Manual of the relevant controller.

If the Alarm information suggests or indicates a serious problem, the operator will be able to give useful information to the Service Centre, thereby reducing down time with relative costs savings.

A00	NONE
A01	CHOPPER RUNNING
A02	NO COMMUNICATION
A03	UNKNOWN CHOPPER
A04	CONSOLE EEPROM
A05	SERIAL ERROR 2
A06	SERIAL ERROR 1
A07	CHOPPER NOT CONFIG
A08	WATCHDOG
A09	FIELD FF FAILURE
A10	EEPROM DATA KO
A11	EEPROM PAR KO
A12	EEPROM CONF KO
A13	EEPROM KO
A14	EEPROM OFFLINE
A15	LOGIC FAILURE 5
A16	LOGIC FAILURE 4
A17	LOGIC FAILURE 3
A18	LOGIC FAILURE 2

A19	LOGIC FAILURE 1
A20	FORW VMN LOW
A21	FORW VMN HIGH
A22	BACK VMN LOW
A23	BACK VMN HIGH
A24	LEFT VMN LOW
A25	LEFT VMN HIGH
A26	RIGHT VMN LOW
A27	RIGHT VMN HIGH
A28	PUMP VMN LOW
A29	PUMP VMN HIGH
A30	VMN LOW
A31	VMN HIGH
A32	VMN NOT OK
A33	NO FULL COND
A34	RGT NO FULL COND
A35	LFT NO FULL COND
A36	PU NO FULL COND
A37	CONTACTOR CLOSED
A38	CONTACTOR OPEN
A39	BRAKE DON' T CLOSED
A40	BRAKE CONT OPEN
A41	DIR CONT CLOSED
A42	DIR CONT OPEN
A43	RIGHT CONT CLOSED
A44	RIGHT CONT OPEN
A45	LEFT CONT CLOSED
A46	LEFT CONT OPEN
A47	MAIN CONT CLOSED
A48	MAIN CONT OPEN
A49	I=0 EVER
A50	LEFT I=0 EVER
A51	RIGHT I=0 EVER
A52	PUMP I=0 EVER
A53	STBY I HIGH
A54	LEFT STBY I HIGH
A55	RGT STBY I HIGH
A56	PUMP STBY I HIGH
A57	HIGH FIELD CURR
A58	NO FIELD CURR
A59	HIGH BRAKING I
A60	CAPACITOR CHARGE
A61	HIGH TEMPERATURE
A62	TH PROTECTION
A63	THERMIC LEVEL 2
A64	PUMP TEMPERATURE
A65	MOTOR TEMPERATURE
A66	BATTERY LOW
A67	BATTERY LEVEL 2
A68	BATTERY LEVEL 1
A69	CURRENT SENS KO
A70	POWER FAILURE 4
A71	POWER FAILURE 3

A72	POWER FAILURE 2
A73	POWER FAILURE 1
A74	DRIVER SHORTED
A75	CONTACTOR DRIVER
A76	COIL SHORTED
A77	COIL INTERRUPTED
A78	VACC NOT OK
A79	INCORRECT START
A80	FORW + BACK
A81	BAD STEER 0 SET
A82	ENCODER ERROR
A83	BAD ENCODER SIGN
A84	STEER SENS KO
A85	STEER HAZARD
A86	PEDAL WIRE KO
A87	PEDAL FAILURE
A88	TRACTION BRUSHES
A89	PUMP BRUSHES
A90	DRIVER 1 KO
A91	DRIVER 2 KO
A92	DRIVER 1 SIC KO
A93	DRIVER 2 SIC KO
A94	INPUT ERROR 6
A95	INPUT ERROR 5
A96	INVERSION
A97	POSITION HANDLE
A98	INPUT ERROR 2
A99	INPUT ERROR 1



The 16A06 string corresponds to the NO COMMUNICATION alarm. It is the only MDI-CAN alarm and it indicates a problem in the communication with the traction controller. Check the connections between MDI-CAN and controller.

Important:

The alarms reported in the previous tables are referred to Zapi standard coding. Customized software or special products can have same changes in the alarms indications.